

## BRAKE MOTORS



## TECHNICAL DESCRIPTION - AMBY SERIES

### THREE-PHASE BRAKE MOTOR WITH HIGH-TORQUE D.C. BRAKE

Frame sizes 63 ... 160

Output range 0.12 ... 22kW

Polarity 2, 4, 6, 8 (pole-changing on request)

Insulation class F

Standard degree of protection: IP 54 (IP 55 on request) for frame size ≤ 132, IP 55 for frame size 160

Double braking surface

Asbestos-free friction surfaces

Electromagnetic spring-loaded brake with release in case of power supply interruption

Standard rectifier supply 230 V - 50/60 Hz (others on request)

Progressive and noiseless braking

High braking torque ( $M_b \approx 1,5 M_N$ )

Step adjustment braking torque (33%; 67%; 100%  $M_{b\max}$ )

Fast acting rectifier available on request only for rectifier supply 230V 50/60Hz (sizes 63 ... 112)

Special execution for wind generator available on request (continuous braking torque adjustment (in the range 30%  $M_{b\max}$  - 100%  $M_{b\max}$ ), antisticking execution, corrosion resistance execution, reduced braking torque value, reduced range braking torque regulation, )

cURus approval on request

Efficiency class conform to Energy cURus on request

Available with a large number of options (i.e. encoder, axial independent cooling fan, hand release lever, special brake designs, flywheel, )

High number of starts/hour

Typical applications

Automation requiring a smooth intervention, transfer machinery, packaging machinery, gearmotors.

### TABLE OF THE MAIN BRAKE FEATURES

Brake size	Motor size	$M_b^{1)}$ Nm braking spring number					Air gap mm	Brake absorption on dc side @ rectifier input 230V 50/60Hz
		2	3	4	6	9		
12 MV	63	1.8		3.5			0.25 - 0.5	0.1 A
12 MV	71	1.8		3.5			0.25 - 0.5	0.1 A
53 MV		2.5		5	7.5		0.25 - 0.5	0.14 A
13 MV	80	2.5		5	7.5		0.25 - 0.5	0.14 A
04 MV		5		10	15		0.3 - 0.55	0.17 A
14 MV	90	5		10	15		0.3 - 0.55	0.17 A
05 MV		13		26	40		0.3 - 0.55	0.23 A
15 MV	100	13		26	40		0.3 - 0.55	0.23 A
56S MV		25		50	75		0.35 - 0.6	0.34 A
15 MV	112	13		26	40		0.3 - 0.55	0.23 A
56S MV		25		50	75		0.35 - 0.6	0.34 A
16S MV	132	25		50	75		0.35 - 0.6	0.54 A
07 MV		50		100	150		0.4 - 0.8	0.7 A
17 MV	160	50		100	150		0.4 - 0.8	0.7 A
08 MV			85		170	250	0.5 - 0.9	1.2 A

1) Rated values ± 20%

For delays of release/braking consult us

For max friction work for each braking consult us

# SPARE PARTS FOR AMBY MOTORS

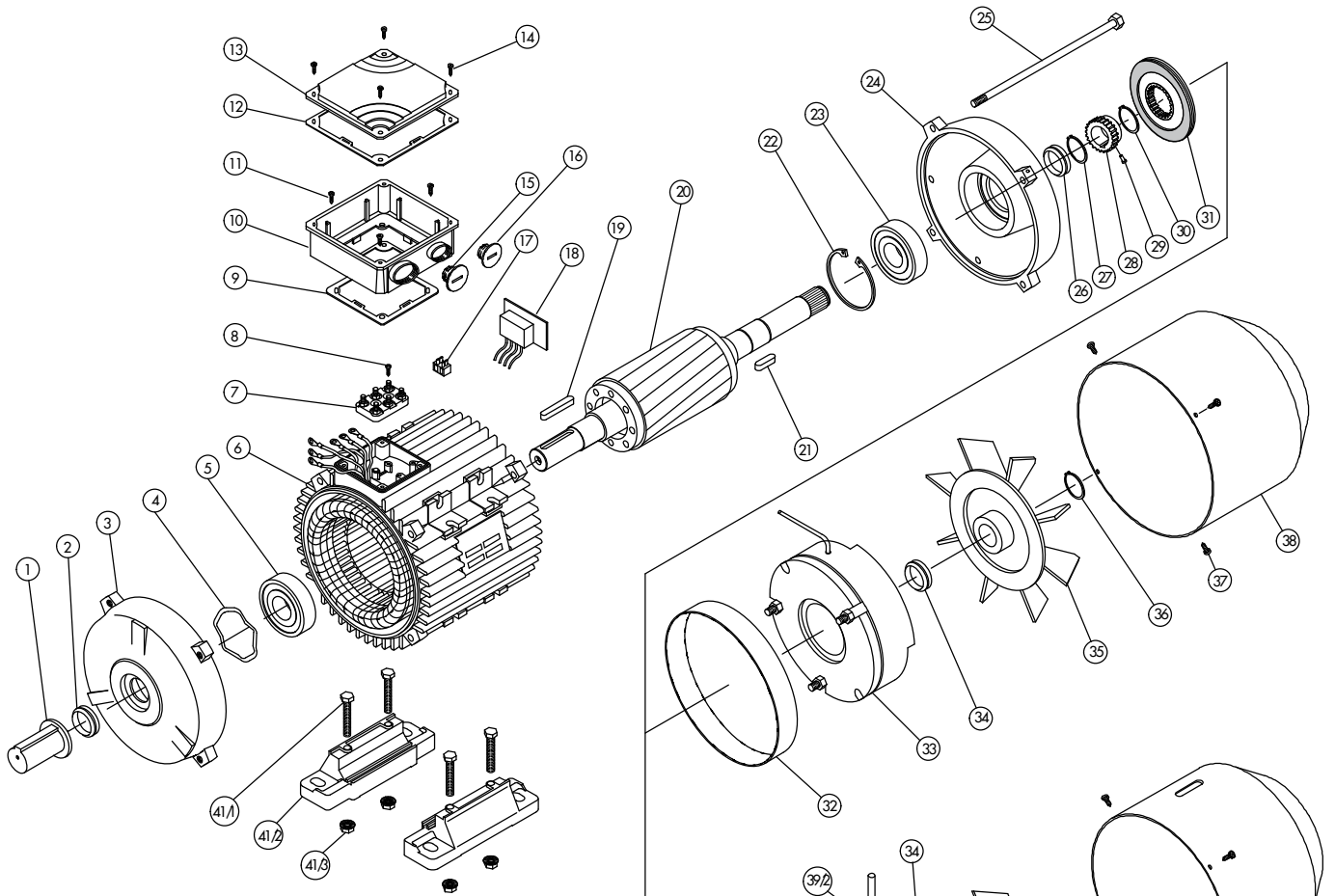

## PART DESCRIPTION

- 1 Shaft protection
- 2 Dust seal drive end
- 3 Endshield drive end
- 4 Pre-load washer
- 5 Bearing drive end
- 6 Stator frame
- 7 Motor terminal board
- 8 Fixing screw motor terminal board
- 9 Gasket terminal box
- 10 Terminal box
- 11 Fixing screw terminal box
- 12 Gasket terminal box lid
- 13 Terminal box lid
- 14 Fixing screw terminal box lid
- 15 Blank gland plug
- 16 Blank gland plug
- 17 Brake terminal board (for sizes 63 ÷ 112<sup>a)</sup>)
- 18 Rectifier
- 19 Motor key
- 20 Rotor complete
- 21 Brake key
- 22 Circlip
- 23 Bearing non-drive end
- 24 Endshield non-drive end<sup>b)</sup>
- 25 Tie rod
- 26 Dust seal (for IP55 only)
- 27 Circlip
- 28 Brake hub
- 29 Anti-vibration spring/O-ring
- 30 Circlip
- 31 Brake disk
- 32 Brake gasket (for IP55 only)
- 33 Preassembled part of the brake (electromagnet, brake anchor, braking springs, fixing screws, guiding pipes, fastening nuts)

- 34 Dust seal (for IP55 only)
- 35 Fan
- 36 Circlip (only for sizes 100 and 112)
- 37 Fixing screw fan cover
- 38 Fan cover
- 39 Hand release<sup>☒</sup>
  - 39/1 hand lever
  - 39/2 releasing lever
  - 39/3 regulation/fixing kit
- 40 Fan cover for hand release
- 41 Foot kit (1 foot)<sup>☒</sup>
  - 41/1 fixing screw
  - 41/2 foot
  - 41/3 fixing nut<sup>c)</sup>

a) for sizes ÷112 brake terminal board is on the rectifier

b) for sizes 63 and 71 with braking flange

c) for sizes 132-160 washer and nut

## TECHNICAL DESCRIPTION - AMBZ SERIES

### THREE-PHASE BRAKE MOTOR WITH HIGH-TORQUE A.C. BRAKE

Frame sizes 63 ... 160

Output range 0.12 ... 22kW

Polarity 2, 4, 6, 8 (pole-changing on request)

Insulation class F

Standard degree of protection IP 54 (IP 55 on request) for frame size 132, IP 55 for frame size 160

Double braking surface

Asbestos-free friction surfaces

Electromagnetic spring-loaded brake with release in case of power supply interruption

Standard brake supply 230/400V - 50Hz (others on request) with separate terminal block

High braking torque ( $M_b \approx 1.5 M_N$ )

Step adjustment braking torque as standard according to table below (33%; 67%; 100%  $M_{b\ max}$ )

Special execution for wind generator available on request (continuous braking torque adjustment (in the range 30%  $M_{b\ max}$  - 100%  $M_{b\ max}$ ), antisticking execution, corrosion resistance execution, reduced braking torque value, reduced range braking torque regulation, )

cURus approval on request

Efficiency class conform to Energy cURus on request

Available with a large number of options (i.e. encoder, axial independent cooling fan, hand release lever, special brake designs, flywheel, )

Very high number of starts/hour

Typical applications

Automation with high intervention frequency, gearmotors, lifting, handling machinery.

### TABLE OF THE MAIN BRAKE FEATURES

Brake size	Motor size	$M_b^{1)}$ Nm			Air gap mm	Brake absorption @ 230/400V 50Hz
		min	average	max (std)		
12 MS/MV	63	1.8		3.5	0.25 - 0.5	0.18/0.1
12 MS/MV	71	1.8		3.5	0.25 - 0.5	0.18/0.1
53 MS/MV		2.5	5	7.5	0.25 - 0.5	0.2/0.12
13 MS/MV	80	2.5	5	7.5	0.25 - 0.5	0.2/0.12
04 MS/MV		5	10	15	0.3 - 0.55	0.28/0.16
14 MS/MV	90	5	10	15	0.3 - 0.55	0.28/0.16
05 MS/MV		13	26	40	0.3 - 0.55	0.63/0.36
15 MS/MV	100	13	26	40	0.3 - 0.55	0.63/0.36
56S MS/MV		25	50	75	0.35 - 0.6	1.2/0.68
15 MS/MV	112	13	26	40	0.3 - 0.55	0.63/0.36
56S MS/MV		25	50	75	0.35 - 0.6	1.2/0.68
16S MS/MV	132	25	50	75	0.35 - 0.6	1.2/0.68
07 MS/MV		50	100	150	0.4 - 0.8	1.5/0.87
17 MS/MV	160	50	100	150	0.4 - 0.8	1.5/0.87
08 MS/MV		85	170	250	0.5 - 0.8	1.9/1.1

1) Rated values  $\pm$  20%

For delays of release/braking consult us

For max friction work for each braking consult us

## SPARE PARTS FOR AMBZ MOTORS

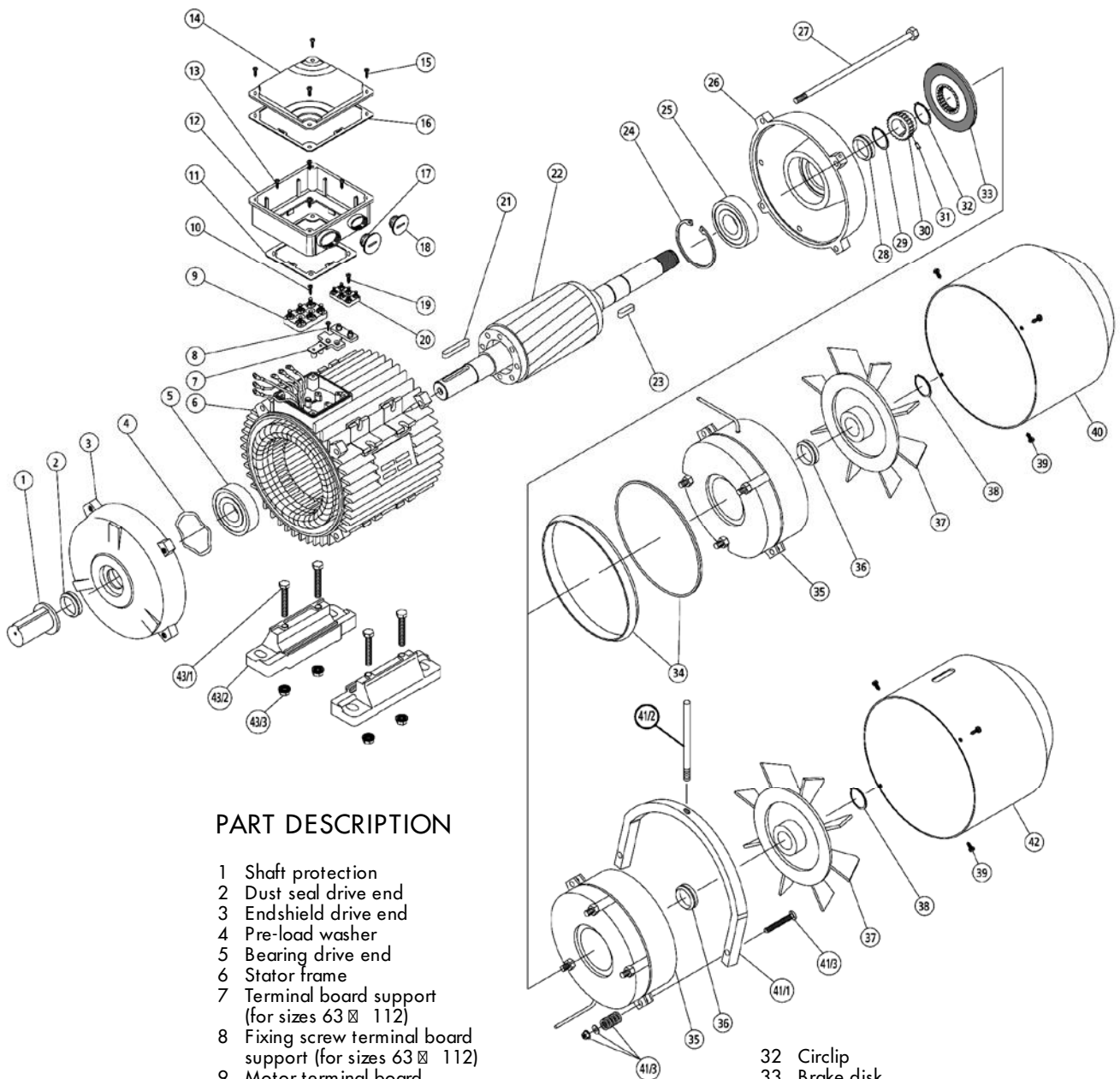

### PART DESCRIPTION

- |    |  |      |  |
|----|--|------|--|
| 1  | Shaft protection   | 32   | Circlip  |
| 2  | Dust seal drive end                                      | 33   | Brake disk   |
| 3  | Endshield drive end                                      | 34   | Brake gasket (for IP55 only)   |
| 4  | Pre-load washer  | 35   | Preassembled part of the brake (electromagnet, brake anchor, braking springs, fixing screws, guiding pipes, fastening nuts, spacers) |
| 5  | Bearing drive end  | 36   | Dust seal (for IP55 only)  |
| 6  | Stator frame   | 37   | Fan  |
| 7  | Terminal board support (for sizes 63 x 112)              | 38   | Circlip (only for sizes 100 and 112)   |
| 8  | Fixing screw terminal board support (for sizes 63 x 112) | 39   | Fixing screw fan cover   |
| 9  | Motor terminal board                                     | 40   | Fan cover  |
| 10 | Fixing screw motor terminal board                        | 41   | Hand release   |
| 11 | Gasket terminal box                                      | 41/1 | hand lever   |
| 12 | Terminal box   | 41/2 | releasing lever  |
| 13 | Fixing screw terminal box                                | 41/3 | regulation/fixing kit  |
| 14 | Gasket terminal box lid                                  | 42   | fan cover for hand release   |
| 15 | Terminal box lid   | 43   | foot kit (1 foot)  |
| 16 | Fixing screw terminal box lid                            | 43/1 | fixing screw   |
| 17 | Blank gland plug   | 43/2 | foot   |
| 18 | Blank gland plug   | 43/3 | fixing nut <sup>b)</sup>   |
| 19 | Fixing screw brake terminal board (for sizes 63 x 112)   |      |  |
| 20 | Brake terminal board (for sizes 63 x 112)                |      |  |
| 21 | Motor key  |      |  |
| 22 | Rotor complete   |      |  |
| 23 | Brake key  |      |  |
| 24 | Circlip  |      |  |
| 25 | Bearing non-drive end                                    |      |  |
| 26 | Endshield non-drive end <sup>a)</sup>                    |      |  |
| 27 | Tie rod  |      |  |
| 28 | Dust seal (for IP55 only)                                |      |  |
| 29 | Circlip  |      |  |
| 30 | Brake hub  |      |  |
| 31 | Anti-vibration spring/O-ring                             |      |  |

a) for sizes 63 and 71 with braking flange

b) for size ≥ 132 washer and nut

## TECHNICAL DESCRIPTION - AMS SERIES

### THREE-PHASE BRAKE MOTOR WITH LOW-TORQUE D.C. BRAKE WITH REDUCED OVERALL DIMENSIONS

Frame sizes 63 - 160  
 Output range 0.12 - 22 kW  
 Polarity 2, 4, 6, 8 (pole changing on request)  
 Insulation class F  
 IP 54 as standard degree of protection (IP 55 on request)  
 Electromagnetic spring-loaded brake with release in case of power supply interruption  
 Standard rectifier supply 230 V - 50/60 Hz (others on request)  
 Standard version for easy air gap adjustment (version for manual rotation of the shaft front N-end available on request for size 63 ... 132)  
 Single braking surface  
 Asbestos-free friction surfaces  
 Non adjustable braking torque ( $M_b \leq M_N$ )  
 Soft, progressive and noiseless braking  
 Very reduced overall dimensions (similar to standard motors series AM)  
 Increased braking torque (+50% of the catalogue value) available on request  
 Fast acting rectifier available on request only for rectifier supply 230V 50/60Hz  
 cURus Approval on request  
 Efficiency class conform to Energy cURus on request  
 Available with a large range of options (i.e. encoder, axial independent cooling fan, hand release lever, )

Typical applications  
 Woodworking/cutting machinery, machinery requiring long braking periods and high braking duties.

### TABLE OF THE MAIN BRAKE FEATURES

Brake size	Motor size	$M_b$ <sup>1)</sup> Nm	Air gap mm	Brake absorption I <sub>A</sub> on dc side @ rectifier input 230V 50/60Hz
63	63	3	0.25 - 0.5	0.1 A
71	71	4	0.25 - 0.5	0.1 A
80	80	7	0.25 - 0.5	0.16 A
90	90	7	0.25 - 0.5	0.16 A
100	100	13	0.3 - 0.55	0.2 A
	112	13	0.3 - 0.55	0.2 A
132 L	132	30	0.35 - 0.6	0.27 A
	160	30	0.35 - 0.6	0.27 A

1) Rated values ± 20%

For delays of release/braking consult us

For max friction work for each braking consult us



# SPARE PARTS FOR AMS MOTORS FOR EASY AIR GAP ADJUSTMENT <sup>1)</sup>

1) AMS for manual rotation of the shaft from NDE available on request

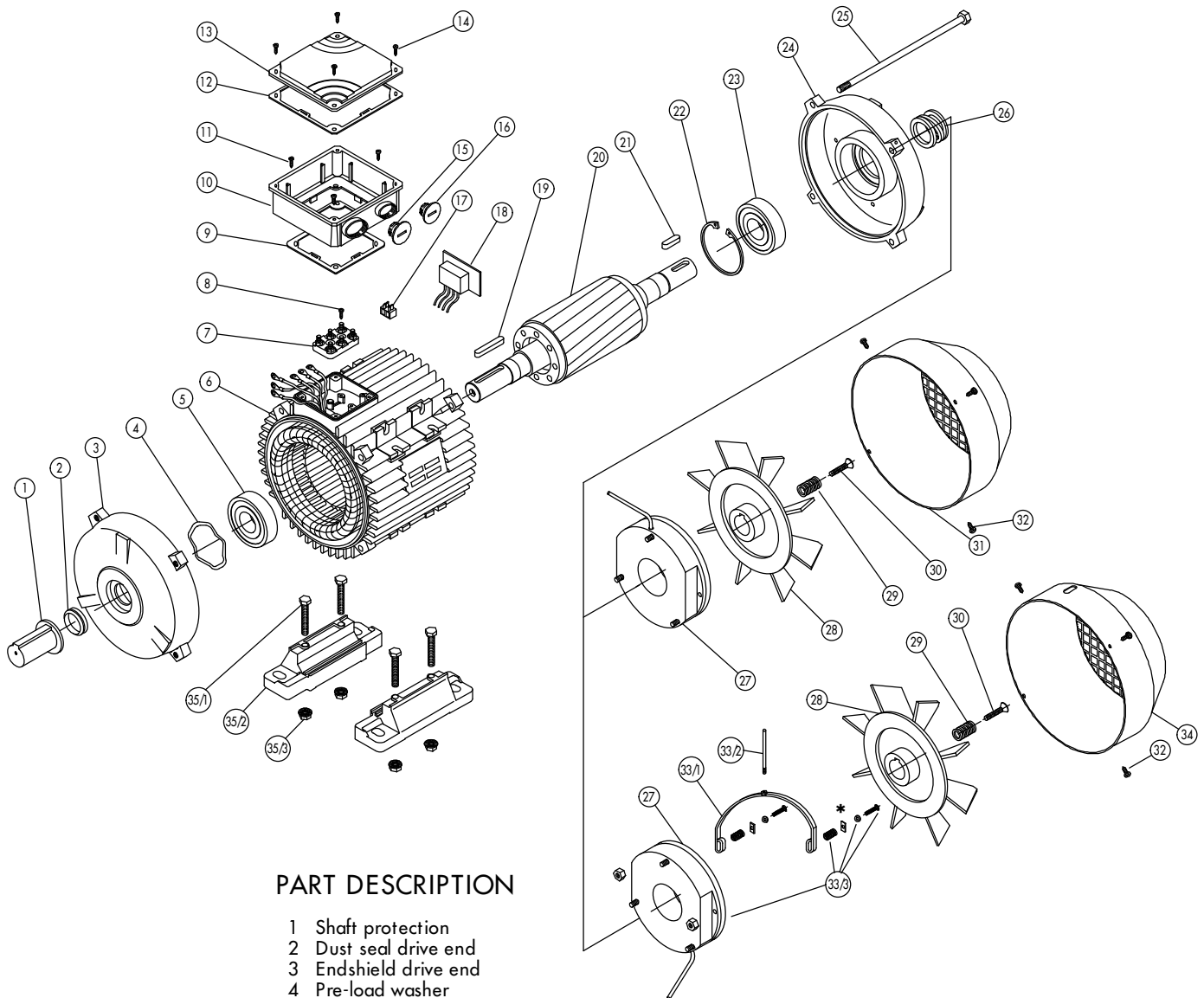

## PART DESCRIPTION

- |    |  |      |   |
|----|--|------|---|
| 1  | Shaft protection   | 28   | Brake fan (with fixed washer)                         |
| 2  | Dust seal drive end  | 29   | Auxiliary contrast spring                             |
| 3  | Endshield drive end  | 30   | Air gap adjustment/fixing screw                       |
| 4  | Pre-load washer  | 31   | Fan cover   |
| 5  | Bearing drive end  | 32   | Fixing screw fan cover                                |
| 6  | Stator frame   | 33   | Hand release  |
| 7  | Motor terminal board   | 33/1 | hand lever  |
| 8  | Fixing screw motor terminal board  | 33/2 | releasing lever                                       |
| 9  | Gasket terminal box  | 33/3 | regulation/fixing kit                                 |
| 10 | Terminal box   | 34   | Fan cover for hand release                            |
| 11 | Fixing screw terminal box  | 35   | Foot kit (1 foot) (for sizes 71 & 132 <sup>a)</sup> ) |
| 12 | Gasket terminal box lid  | 35/1 | fixing screw  |
| 13 | Terminal box lid   | 35/2 | foot  |
| 14 | Fixing screw terminal box lid  | 35/3 | fixing nut <sup>b)</sup>                              |
| 15 | Blank gland plug   |      |   |
| 16 | Blank gland plug   |      |   |
| 17 | Brake terminal board   |      |   |
| 18 | Rectifier  |      |   |
| 19 | Motor key  |      |   |
| 20 | Rotor complete   |      |   |
| 21 | Brake key  |      |   |
| 22 | Circlip  |      |   |
| 23 | Bearing non-drive end  |      |   |
| 24 | Endshield non-drive end  |      |   |
| 25 | Tie rod  |      |   |
| 26 | Main contrast spring   |      |   |
| 27 | Preassembled part of the brake (electromagnet, brake anchor with friction surface, braking springs, fixing screws) |      |   |
|    |  | a)   | for size 63 feet integral with the case               |
|    |  | b)   | for size 132 washer and nut                           |

## CONNECTION DIAGRAMS

Every brake motors has got, inside the terminal box, the connection diagram both for the motor and for the brake/rectifier.

For brake motors with ac brakes (AMBZ series) the connection diagram is

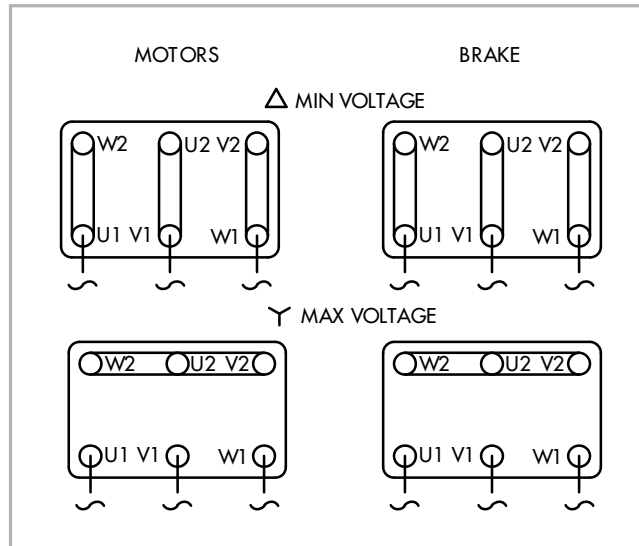



## CONNECTION DIAGRAMS

For brake motors with dc brake (AMS and AMBY series) required at 230/400V 50Hz, the rectifier is directly connected to the motor terminal block as follows

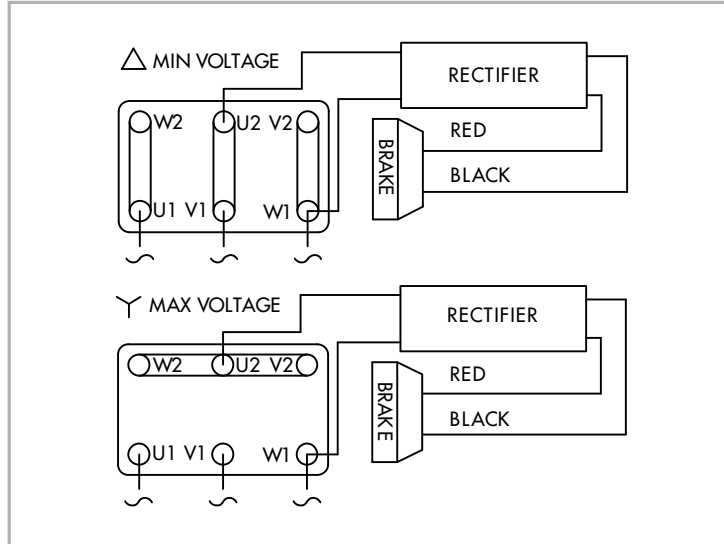

For AMS (63 ... 160) and AMBY (63 ... 112)

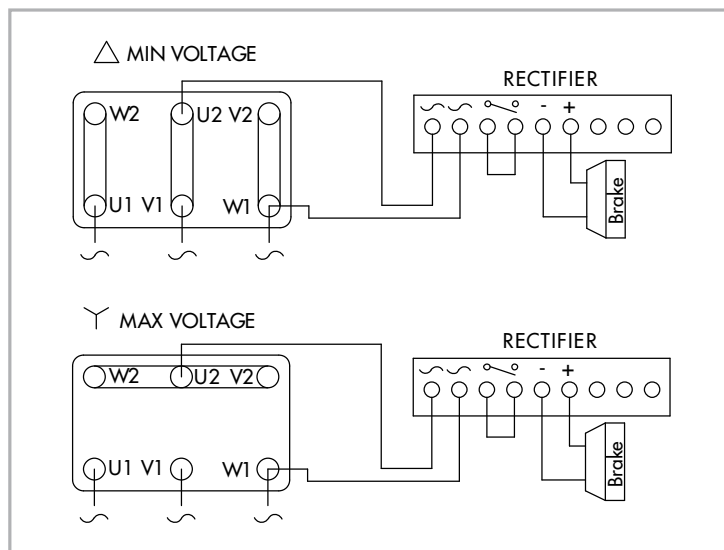

For AMBY 132-160

## CONNECTION DIAGRAMS

For all other supply value, different from 230/400V 50Hz, since the standard rectifier supply is 230V 50/60Hz, and when an inverter supply is used the rectifier has to be separately supplied according to the diagrams☒

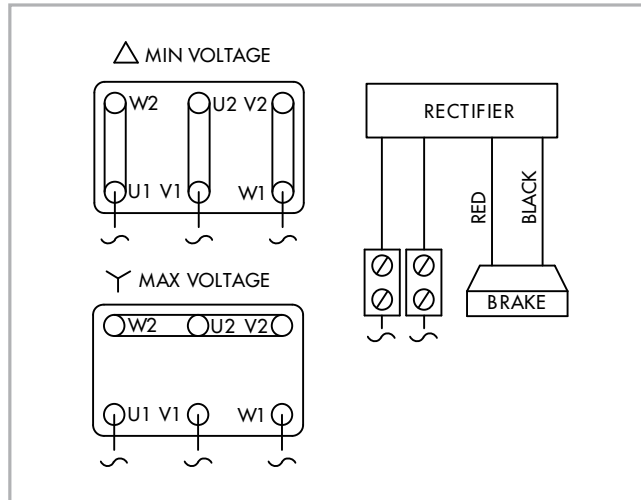

For AMS (63 ... 160) and AMBY (63 ...112)

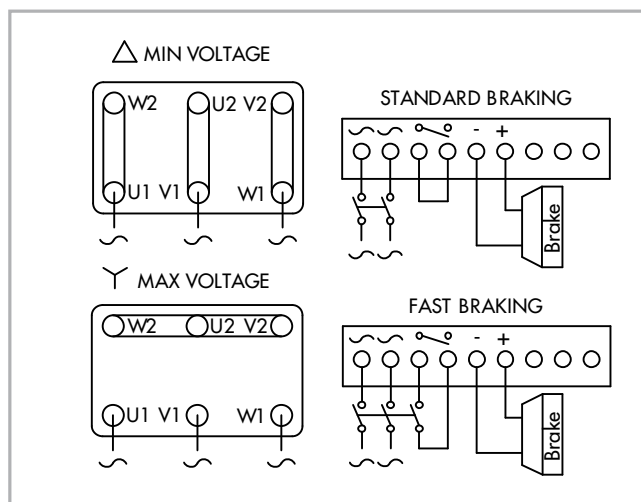

For AMBY 132-160

Supplying the rectifier separately from the motor terminal block allows to reduce the delay of braking; to achieve the fast braking on AMBY132-160 it is necessary to open even the dc side of the brake coil (according to previous figure).

In case of pole-changing brake motors☒for motor connection see three phase motors section , the brake/rectifier has to be supplied separately.

Warning☒for the correct supply of both motor and brake refer to the values written on nameplate.

## TYPE DESIGNATION

Apart from other information, it is necessary to specify the exact type designation in all enquiries, when ordering spare parts or replacement motors or when asking for documentary information.

The type designation of our brake motors comprises 10 points of reference, each of which may consist of several letters and/or numerals. The meaning of each symbol can be seen from the following table. For motors not included in our standard range, special symbols may be used which are not listed here

Ref. point	Meaning	Description of symbols used for our motors	
1	Type of motor	A	Asynchronous motor
2	Cooling	M G1) MFV	Surface cooled with external fan, cooling fins Surface cooled without external fan, cooling fins Surface cooled with forced ventilation, cooling fins
3	Type of motor	blank HE	Three-phase motors, standard efficiency IE1 code Three-phase motors, high efficiency IE2 code
4	Type of brake	BY BZ S	High-torque dc brake High-torque ac brake Low-torque dc brake
5	Shaft centre height	63, 71, 80, 90, 100, 112, 132, 160	
6	Frame length	Z S M L	Mechanical dimension (short) Mechanical dimension (medium) Mechanical dimension (long)
7	Mechanical design and output power	A ... ... Z	
8	Frame material	A	Aluminium frame
9	Number of poles	2 4 6 8	(pole-changing on request)
10	Special features	R3	High resistance rotor

1) For AMBY and AMBZ type only

### Example

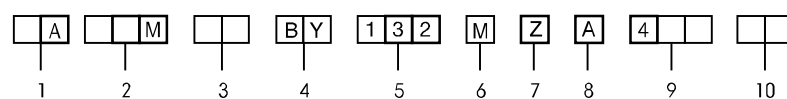

# STANDARD EFFICIENCY BRAKE MOTORS - IE1

EFFICIENCY LEVEL ACCORDING TO IEC 60034-30:2008  
EFFICIENCY TESTING METHOD IEC 60034-2-1;2007

IE code not applicable to motors 2, 4, 6 poles with PN  $\geq$  0.75 kW. Efficiency testing method IEC 60034-2;1996

FOR MAINS VOLTAGE  
400 V - 50 HZ

# IE1

Type	kW	HP	min <sup>-1</sup>	M <sub>N</sub> Nm	IE1 $\eta$			cos $\varphi$	I <sub>N</sub>		I <sub>A</sub> /I <sub>N</sub>	M <sub>A</sub> /M <sub>N</sub>	M <sub>K</sub> /M <sub>N</sub>	
					50%	75%	100%		400V	380-420V				
3000 min <sup>-1</sup> (2 poles)														
AM... 63Z AA	2	0.18	0.25	2790	0.6	54.0	58.0	63.0	0.73	0.60	0.65	3.7	3.0	3.1
AM... 63Z BA	2	0.25	0.33	2790	0.9	57.0	62.0	66.0	0.70	0.80	0.75	4.5	3.2	3.3
AM... 63Z CA	2*	0.37	0.5	2800	1.3	54.0	58.0	65.0	0.70	1.20	1.25	4.6	3.4	3.4
AM... 71Z AA	2	0.37	0.5	2820	1.3	58.0	64.0	70.0	0.78	1.0	1.2	4.7	3.6	3.6
AM... 71Z BA	2	0.55	0.75	2830	1.9	57.0	64.0	71.0	0.77	1.5	1.6	4.8	3.2	3.3
AM... 71Z CA	2*	0.75	1	2800	2.6	58.9	65.7	72.6	0.76	2.0	2.1	5.2	3.1	3.1
AM... 80Z AA	2	0.75	1	2840	2.5	66.3	71.5	73.0	0.78	1.9	2.0	5.0	2.8	2.9
AM... 80Z BA	2	1.1	1.5	2810	3.7	72.1	75.0	75.3	0.82	2.5	2.6	4.6	2.4	2.9
AM... 80Z CA	2*	1.5	2	2825	5.1	74.7	77.5	77.8	0.83	3.3	3.4	5.0	2.9	3.3
AM... 90S AA	2	1.5	2	2830	5.1	75.6	78.7	78.6	0.82	3.4	3.5	5.0	3.1	3.0
AM... 90S BA	2*	1.8	2.5	2805	6.1	74.9	78.0	78.2	0.80	4.2	4.3	4.5	2.6	2.5
AM... 90L CA	2	2.2	3	2860	7.3	81.5	82.8	81.8	0.81	4.9	4.9	7.1	4.1	4.0
AM... 90L DA	2*	3	4	2860	10.0	78.7	81.8	82.2	0.80	6.6	6.8	7.2	3.9	3.8
AM... 100L AA	2	3	4	2860	10.0	78.9	81.4	81.5	0.85	6.4	6.7	6.0	3.1	3.3
AM... 100L BA	2*	4	5.5	2835	13.5	81.1	82.5	81.7	0.88	8.0	8.1	6.2	2.9	2.9
AM... 100L CA	2*	5.5	7.5	2865	18.3	83.7	84.6	83.3	0.86	11.1	11.3	7.2	3.5	4.1
AM... 112M AA	2	4	5.5	2880	13.3	81.9	84.0	83.5	0.82	8.4	8.7	8.0	3.4	3.6
AM... 112M BA	2*	5.5	7.5	2900	18.1	83.6	84.7	85.0	0.86	10.9	11.2	7.8	3.5	3.6
AM... 112M CA	2*	7.5	10	2900	24.7	86.7	87.8	87.1	0.87	14.3	14.8	8.7	4.0	4.0
AM... 132S YA	2	5.5	7.5	2890	18.2	83.2	84.7	85.0	0.83	11.3	11.4	6.0	2.2	2.3
AM... 132S ZA	2	7.5	10	2880	24.9	85.6	86.7	86.1	0.87	14.5	14.9	6.4	2.9	3.1
AM... 132M ZA	2*	9.2	12.5	2900	30.3	84.7	86.8	87.0	0.84	18.4	18.8	7.0	2.8	3.2
AM... 132M RA	2*	11	15	2880	36.5	87.1	88.1	88.0	0.85	21.3	21.7	6.9	3.2	3.8
AM... 132M TA	2*	15	20	2920	49.1	86.4	88.6	88.9	0.83	29.5	30.5	7.0	3.2	3.7
AM... 160M VA	2	11	15	2940	35.7	83.4	86.4	87.7	0.83	21.9	22.7	7.4	2.5	3.1
AM... 160M XA	2	15	20	2940	48.7	87.3	88.9	88.9	0.85	28.6	29.2	8.1	3.1	3.7
AM... 160L XA	2	18.5	25	2950	59.9	88.2	89.7	89.6	0.87	34.3	34.8	8.5	3.6	4.2
AM... 160L RA	2*	22	30	2940	71.5	88.7	90.5	90.4	0.90	39.1	39.4	8.4	3.0	3.7

\* Higher output (progressive motor)

For maximum friction work per stop consult us

# STANDARD EFFICIENCY BRAKE MOTORS – IE1

AMBY SERIES – HIGH TORQUE - DC BRAKE

AMBZ SERIES – HIGH TORQUE - AC BRAKE

AMS SERIES – LOW TORQUE - DC BRAKE

## IE1

Type	AMBY					AMBZ					AMS				
	J 10 <sup>-3</sup> kgm <sup>2</sup>	M <sub>b</sub> max Nm	z <sub>L</sub> <sup>1)</sup> c/h	kg		J 10 <sup>-3</sup> kgm <sup>2</sup>	M <sub>b</sub> max Nm	z <sub>L</sub> <sup>1)</sup> c/h	kg		J 10 <sup>-3</sup> kgm <sup>2</sup>	M <sub>b</sub> Nm	z <sub>L</sub> <sup>1)</sup> c/h	kg	
3000 min <sup>-1</sup> (2 poles)															
AM... 63Z AA	2	0.19	3.5	6300	5.7	0.19	3.5	7100	5.5		0.43	3	3550	5.1	
AM... 63Z BA	2	0.21	3.5	6300	6.2	0.21	3.5	7100	6.0		0.45	3	3150	5.6	
AM... 63Z CA	2*	0.24	3.5	6000	6.5	0.24	3.5	6700	6.3		0.48	3	3150	5.9	
AM... 71Z AA	2	0.38	3.5(7.5) <sup>2)</sup>	5000	8.2	0.38	3.5(7.5) <sup>2)</sup>	5600	8.0		0.81	4	2650	7.6	
AM... 71Z BA	2	0.48	7.5	4750	9.3	0.48	7.5	5300	9.0		0.87	4	2650	8.0	
AM... 71Z CA	2*	0.57	7.5	4500	10.3	0.57	7.5	5000	10.0		0.96	4	2360	9.0	
AM... 80Z AA	2	0.70	7.5(15) <sup>2)</sup>	3350	12.6	0.70	7.5(15) <sup>2)</sup>	3750	12.3		1.59	7	1700	11.2	
AM... 80Z BA	2	0.91	15	3150	14.6	0.91	15	3550	14.5		1.75	7	1700	12.3	
AM... 80Z CA	2*	1.07	15	2650	16.2	1.07	15	3000	16.1		1.91	7	1400	13.9	
AM... 90S AA	2	1.39	15(40) <sup>2)</sup>	3150	18.7	1.39	15(40) <sup>2)</sup>	3550	18.6		2.31	7	1400	15.7	
AM... 90S BA	2*	1.39	15(40) <sup>2)</sup>	3150	18.7	1.39	15(40) <sup>2)</sup>	3550	18.6		2.31	7	1400	15.7	
AM... 90L CA	2	1.84	15(40) <sup>2)</sup>	2500	22.0	1.84	15(40) <sup>2)</sup>	2800	21.9		2.76	7	1200	19.0	
AM... 90L DA	2*	2.32	40	2360	26.5	2.32	40	2650	27.2		3.06	7	1120	21.7	
AM... 100L AA	2	2.71	40(75) <sup>2)</sup>	2360	27.9	2.71	40(75) <sup>2)</sup>	2650	28.6		5.3	13	1120	23.6	
AM... 100L BA	2*	3.23	40(75) <sup>2)</sup>	2120	28.3	3.23	40(75) <sup>2)</sup>	2360	29.0		5.8	13	1000	24	
AM... 100L CA	2*	4.26	40(75) <sup>2)</sup>	2000	34.5	4.26	40(75) <sup>2)</sup>	2230	35.2		6.9	13	900	30.2	
AM... 112M AA	2	5.0	40(75) <sup>2)</sup>	1120	33.8	5.0	40(75) <sup>2)</sup>	1250	34.5		7.6	13	750	29.0	
AM... 112M BA	2*	6.1	40(75) <sup>2)</sup>	1000	36.9	6.1	40(75) <sup>2)</sup>	1120	37.6		8.7	13	670	32.1	
AM... 112M CA	2*	8.8	75	900	46.5	8.8	75	1000	47.9		10.9	13	600	38.3	
AM... 132S YA	2	10.4	75(150) <sup>2)</sup>	710	55	10.4	75(150) <sup>2)</sup>	800	56		14.2	30	560	46.5	
AM... 132S ZA	2	13.1	75(150) <sup>2)</sup>	670	61	13.1	75(150) <sup>2)</sup>	750	62		17.0	30	480	52	
AM... 132M ZA	2*	14.1	75(150) <sup>2)</sup>	600	66	14.1	75(150) <sup>2)</sup>	670	67		18.0	30	430	57	
AM... 132M RA	2*	16.9	75(150) <sup>2)</sup>	550	70	16.9	75(150) <sup>2)</sup>	610	72		20.8	30	380	62	
AM... 132M TA	2*	22.0	150	500	81	22	150	555	83		- <sup>3)</sup>	- <sup>3)</sup>	- <sup>3)</sup>	- <sup>3)</sup>	
AM... 160M VA	2	35.3	150(250) <sup>2)</sup>	400	104	35.3	150(250) <sup>2)</sup>	445	106		37.2	30	315	87	
AM... 160M XA	2	46.1	150(250) <sup>2)</sup>	350	121	46.1	150(250) <sup>2)</sup>	385	123		48.1	30	300	104	
AM... 160L XA	2	59	150(250) <sup>2)</sup>	335	135	59	150(250) <sup>2)</sup>	370	137		62	30	280	118	
AM... 160L RA	2*	59	150(250) <sup>2)</sup>	335	135	59	150(250) <sup>2)</sup>	370	137		62	30	280	118	

\* Higher output (progressive motor)

1) Max. Number of no-load starts/hour with cyclic duration factor 50%

2) On request

3) Motor not available

# STANDARD EFFICIENCY BRAKE MOTORS - IE1

EFFICIENCY LEVEL ACCORDING TO IEC 60034-30:2008  
EFFICIENCY TESTING METHOD IEC 60034-2-1;2007

IE code not applicable to motors 2, 4, 6 poles with PN  $\geq$  0.75 kW. Efficiency testing method IEC 60034-2;1996

FOR MAINS VOLTAGE  
400 V - 50 HZ

# IE1

Type	kW	HP	min <sup>-1</sup>	M <sub>N</sub> Nm	IE1 $\eta$			cos $\varphi$	I <sub>N</sub>		I <sub>A</sub> /I <sub>N</sub>	M <sub>A</sub> /M <sub>N</sub>	M <sub>K</sub> /M <sub>N</sub>	
					50%	75%	100%		400V	380-420V				
1500 min <sup>-1</sup> (4 poles)														
AM... 63Z AA	4	0.12	0.16	1350	0.8	46.0	50.0	57.0	0.65	0.50	0.55	2.4	2.0	2.0
AM... 63Z BA	4	0.18	0.25	1330	1.3	47.0	50.0	58.0	0.70	0.65	0.70	2.3	1.9	1.9
AM... 63Z CA	4*	0.25	0.33	1360	1.8	49.0	52.5	58.0	0.74	0.85	0.90	2.7	2.2	2.1
AM... 71Z AA	4	0.25	0.33	1340	1.8	55.0	59.0	64.0	0.66	0.90	1.00	3.2	1.9	2.0
AM... 71Z BA	4	0.37	0.5	1370	2.6	60.0	63.0	67.0	0.67	1.20	1.25	3.3	2.2	2.2
AM... 71Z CA	4*	0.55	0.75	1380	3.8	61.0	64.0	69.0	0.68	1.70	1.80	3.6	2.4	2.4
AM... 80Z AA	4	0.55	0.75	1400	3.8	67.0	69.0	70.0	0.72	1.6	1.7	3.6	2.6	2.6
AM... 80Z BA	4	0.75	1.0	1410	5.1	68.7	70.8	72.4	0.72	2.1	2.2	4.4	2.8	2.8
AM... 80Z CA	4*	1.1	1.5	1385	7.6	73.4	75.7	75.2	0.77	2.8	2.9	4.4	2.5	2.6
AM... 90S AA	4	1.1	1.5	1400	7.5	75.8	76.0	75.4	0.78	2.7	2.9	5.2	2.5	2.8
AM... 90L BA	4	1.5	2.0	1400	10.2	77.6	77.8	77.5	0.78	3.6	3.7	5.7	2.8	3.0
AM... 90L CA	4*	1.8	2.5	1380	12.5	76.3	76.5	75.9	0.81	4.2	4.3	5.5	2.7	2.9
AM... 90L DA	4*	2.2	3.0	1400	15.0	78.3	78.5	77.9	0.77	5.3	5.5	4.8	2.9	3.2
AM... 100L AA	4	2.2	3.0	1435	14.6	76.5	79.1	79.9	0.74	5.4	5.6	5.3	2.5	2.7
AM... 100L BA	4	3.0	4.0	1425	20.1	82.0	83.0	81.6	0.78	6.8	6.9	4.6	2.4	2.5
AM... 100L CA	4*	4.0	5.5	1400	27.3	80.8	81.8	80.4	0.78	9.2	9.3	6.0	2.6	2.9
AM... 112M AA	4	4.0	5.5	1430	26.7	83.2	83.9	83.1	0.82	8.5	8.8	6.3	2.2	2.8
AM... 112M BA	4*	5.5	7.5	1430	36.7	84.1	84.8	84.0	0.83	11.4	11.7	6.5	2.2	2.9
AM... 132S ZA	4	5.5	7.5	1430	36.7	87.2	87.1	86.1	0.82	11.3	11.7	5.8	3.0	3.0
AM... 132M ZA	4	7.5	10	1440	49.7	87.3	87.2	86.2	0.83	15.3	15.5	6.8	3.1	3.1
AM... 132M RA	4*	9.2	12.5	1440	61.0	86.5	87.5	87.3	0.86	17.7	17.9	8.0	3.5	3.5
AM... 132M TA	4*	11.0	15	1440	72.9	83.5	83.9	84.5	0.87	21.5	22.0	8.3	3.1	3.3
AM... 160M XA	4	11	15	1460	71.9	88.5	89.3	88.7	0.80	22.4	22.7	7.5	2.5	3.1
AM... 160L XA	4	15	20	1460	98.1	89.4	90.2	89.6	0.84	28.8	29.6	7.0	2.5	3.3
AM ... 160L ZA	4*	18.5	25	1460	121.8	89.9	90.7	90.1	0.84	35.4	36.0	7.6	2.5	3.3
AM ... 160L RA	4*	22	30	1460	143.9	90.4	91.2	90.6	0.86	41.0	42.0	7.8	2.4	3.2

\* Higher output (progressive motor)

For maximum friction work per stop consult us

# STANDARD EFFICIENCY BRAKE MOTORS – IE1

AMBY SERIES – HIGH TORQUE - DC BRAKE

AMBZ SERIES – HIGH TORQUE - AC BRAKE

AMS SERIES – LOW TORQUE - DC BRAKE

## IE1

Type	AMBY					AMBZ					AMS				
	J 10 <sup>-3</sup> kgm <sup>2</sup>	M <sub>b max</sub> Nm	z <sub>L</sub> <sup>1)</sup> c/h	kg		J 10 <sup>-3</sup> kgm <sup>2</sup>	M <sub>b max</sub> Nm	z <sub>L</sub> <sup>1)</sup> c/h	kg		J 10 <sup>-3</sup> kgm <sup>2</sup>	M <sub>b</sub> Nm	z <sub>L</sub> <sup>1)</sup> c/h	kg	
1500 min <sup>-1</sup> (4 poles)															
AM... 63Z AA	4	0.31	3.5	13200	5.4	0.31	3.5	15000	5.2		0.54	3	7500	4.8	
AM... 63Z BA	4	0.35	3.5	12500	6.2	0.35	3.5	14000	6.0		0.59	3	7500	5.6	
AM... 63Z CA	4*	0.38	3.5	11800	6.3	0.38	3.5	13200	6.1		0.61	3	6700	5.7	
AM... 71Z AA	4	0.70	3.5(7.5) <sup>2)</sup>	7500	8.1	0.70	3.5(7.5) <sup>2)</sup>	8500	7.9		1.13	4	5000	7.5	
AM... 71Z BA	4	0.87	7.5	7250	9.1	0.87	7.5	8150	8.8		1.26	4	4850	7.8	
AM... 71Z CA	4*	1.11	7.5	6900	10.4	1.11	7.5	7800	10.1		1.50	4	4500	9.1	
AM... 80Z AA	4	1.49	7.5(15) <sup>2)</sup>	6700	12.4	1.49	7.5(15) <sup>2)</sup>	6700	12.1		2.37	7	4250	11.0	
AM... 80Z BA	4	1.93	15	6300	14.4	1.93	15	6300	14.3		2.77	7	4000	12.1	
AM... 80Z CA	4*	2.33	15	6000	15.7	2.33	15	6000	15.6		3.16	7	3750	13.4	
AM... 90S AA	4	2.36	15(40) <sup>2)</sup>	5000	18.0	2.36	15(40) <sup>2)</sup>	5650	17.9		3.28	7	3550	15.5	
AM... 90L BA	4	3.12	40	4750	21.1	3.12	40	5350	21.8		3.85	7	3350	16.3	
AM... 90L CA	4*	3.69	40	4550	22.3	3.69	40	5150	23.0		4.43	7	3250	17.5	
AM... 90L DA	4*	3.98	40	4300	24.8	3.98	40	4850	25.5		4.71	7	3150	20.0	
AM... 100L AA	4	4.83	40(75) <sup>2)</sup>	4500	28.1	4.83	40(75) <sup>2)</sup>	5050	28.8		7.4	13	2500	23.8	
AM... 100L BA	4	6.08	40(75) <sup>2)</sup>	4250	31.1	6.08	40(75) <sup>2)</sup>	4800	31.8		8.7	13	2350	26.8	
AM... 100L CA	4*	7.24	75	4000	37.0	7.24	75	4500	38.4		9.3	13	2200	29.3	
AM... 112M AA	4	11.60	75	2500	42.4	11.60	75	2800	43.8		13.7	13	1500	34.2	
AM... 112M BA	4*	14.42	75	2240	46.9	14.42	75	2500	48.3		16.5	13	1320	38.7	
AM... 132S ZA	4	22.02	75(150) <sup>2)</sup>	2000	60	22.02	75(150) <sup>2)</sup>	2250	61		25.9	30	1180	51	
AM... 132M ZA	4	28.70	75(150) <sup>2)</sup>	1800	69	28.70	75(150) <sup>2)</sup>	2000	70		32.6	30	1000	60	
AM... 132M RA	4*	33.41	150	1500	87	33.41	150	1690	89		35.9	30	800	74	
AM... 132M TA	4*	33.41	150	1500	87	33.41	150	1690	89		35.9	30	800	74	
AM... 160M XA	4	69	150(250) <sup>2)</sup>	670	115	69	150(250) <sup>2)</sup>	750	118		71	30	560	98	
AM... 160L XA	4	90	150(250) <sup>2)</sup>	600	133	90	150(250) <sup>2)</sup>	675	136		92	30	500	117	
AM... 160L ZA	4*	108	250	580	157	108	250	650	156		105	30	480	126	
AM... 160L RA	4*	120	250	550	168	120	250	600	168		- 3)	- 3)	- 3)	- 3)	

\* Higher output (progressive motor)

1) Max. Number of no-load starts/hour with cyclic duration factor 50%

2) On request

3) Motor not available



# STANDARD EFFICIENCY BRAKE MOTORS - IE1

EFFICIENCY LEVEL ACCORDING TO IEC 60034-30;2008  
EFFICIENCY TESTING METHOD IEC 60034-2-1;2007

IE code not applicable to motors 2, 4, 6 poles with PN  $\geq$  0.75 kW. Efficiency testing method IEC 60034-2;1996

FOR MAINS VOLTAGE  
400 V - 50 HZ

# IE1

Type	kW	HP	min <sup>-1</sup>	M <sub>N</sub> Nm	IE1 $\eta$			cos $\varphi$	I <sub>N</sub>		I <sub>A</sub> /I <sub>N</sub>	M <sub>A</sub> /M <sub>N</sub>	M <sub>K</sub> /M <sub>N</sub>	
					50%	75%	100%		400V	380-420V				
1000 min <sup>-1</sup> (6 poles)														
AM 71Z AA	6	0.18	0.25	880	2.0	46.0	48.0	53.0	0.60	0.85	0.9	2.2	1.6	1.6
AM 71Z BA	6	0.25	0.33	880	2.7	46.0	50.0	54.0	0.62	1.10	1.2	2.5	1.7	1.7
AM 80Z AA	6	0.37	0.5	920	3.8	47.0	58.0	60.0	0.70	1.25	1.3	2.7	1.6	2.1
AM 80Z BA	6	0.55	0.75	920	5.7	60.0	64.0	68.0	0.67	1.75	1.8	2.9	2.2	2.1
AM 90S AA	6	0.75	1	910	7.9	70.5	72.5	71.5	0.63	2.4	2.5	2.9	1.7	1.7
AM 90L BA	6	1.1	1.5	920	11.4	72.0	73.5	73.0	0.66	3.3	3.4	3.0	1.7	1.7
AM 100L AA	6	1.5	2	930	15.4	73.3	75.8	75.3	0.69	4.2	4.4	3.7	1.8	2.3
AM 100L BA	6*	1.8	2.5	940	18.3	74.6	77.1	76.6	0.67	5.1	5.3	4.2	2.4	2.8
AM 112M AA	6	2.2	3	940	22.4	77.0	79.0	78.0	0.74	5.3	5.4	4.4	2.4	2.6
AM 112M CA	6*	3	4	940	30.5	81.8	82.8	82.8	0.74	7.0	7.2	5.3	2.9	2.9
AM... 132S ZA	6	3	4	950	30.2	79.5	81.5	81.3	0.72	7.4	7.5	4.9	2.0	2.4
AM... 132M YA	6	4	5.5	950	40.2	81.4	83.1	82.7	0.71	9.9	10.5	4.5	2.2	2.5
AM... 132M ZA	6	5.5	7.5	950	55.3	82.2	83.6	83.6	0.71	13.5	13.5	4.1	2.2	2.2
AM... 160M ZA	6	7.5	10	970	73.8	84.4	86.5	86.3	0.78	16.0	16.3	6.2	2.8	3.2
AM... 160L ZA	6	11	15	960	109.4	88.1	88.5	87.8	0.78	23.4	24.0	6.0	2.5	3.5

\* Higher output (progressive motor)

## EFFICIENCY TESTING METHOD IEC 60034-2;1996

Type	kW	HP	min <sup>-1</sup>	M <sub>N</sub> Nm	$\eta$			cos $\varphi$	I <sub>N</sub>		I <sub>A</sub> /I <sub>N</sub>	M <sub>A</sub> /M <sub>N</sub>	M <sub>K</sub> /M <sub>N</sub>	
					50%	75%	100%		400V	380-420V				
750 min <sup>-1</sup> (8 poles)														
AM 71Z AA	8	0.12	0.16	670	1.7	40	44	50	0.55	0.65	0.70	2.4	2.5	2.5
AM 80Z AA	8	0.25	0.33	680	3.5	40	47	51	0.62	1.1	1.2	2.2	1.8	2.0
AM 90S AA	8	0.37	0.5	680	5.2	52	58	59	0.53	1.7	1.8	2.1	1.4	1.6
AM 90L BA	8	0.55	0.75	680	7.7	52	58	59	0.54	2.5	2.7	2.1	1.4	1.6
AM 100L AA	8	0.75	1.0	690	10.4	59	64	65	0.65	2.6	2.8	3.0	1.6	1.7
AM 100L BA	8	1.1	1.5	690	15.2	59	67	68	0.62	3.9	4.0	3.0	1.9	1.6
AM 112M AA	8	1.5	2.0	696	20.6	66	69	70	0.66	4.6	4.8	4.0	1.8	2.4
AM... 132S ZA	8	2.2	3.0	710	29.6	79.3	80.5	78.8	0.64	6.40	6.6	3.4	1.7	1.7
AM... 132M ZA	8	3.0	4.0	710	40.4	81.3	82.0	79.8	0.67	8.10	8.4	3.6	1.7	1.9
AM... 160M YA	8	4.0	5.5	700	54.6	84.9	84.5	84.4	0.72	9.50	9.7	4.5	1.8	2.2
AM... 160M ZA	8	5.5	7.5	720	72.9	85.6	85.2	85.0	0.73	12.80	13.3	4.0	1.8	2.3

For maximum friction work per stop consult us

# STANDARD EFFICIENCY BRAKE MOTORS – IE1

AMBY SERIES – HIGH TORQUE - DC BRAKE

AMBZ SERIES – HIGH TORQUE - AC BRAKE

AMS SERIES – LOW TORQUE - DC BRAKE

## IE1

Type	AMBY					AMBZ					AMS			
	J	$M_b$	$z_L$			J	$M_b$	$z_L$			J	$M_b$	$z_L$	
	$10^{-3} \text{ kgm}^2$	Nm	c/h	kg		$10^{-3} \text{ kgm}^2$	Nm	c/h	kg		$10^{-3} \text{ kgm}^2$	Nm	c/h	kg
1000 min <sup>-1</sup> (6 poles)														
AM... 71Z AA	6	1.14	7.5	16000	9.2	1.14	7.5	18000	8.9		1.53	4	10000	7.9
AM... 71Z BA	6	1.30	7.5	15000	9.7	1.30	7.5	16800	9.4		1.68	4	9500	8.4
AM... 80Z AA	6	1.94	7.5(15) <sup>2)</sup>	9000	12.2	1.94	7.5(15) <sup>2)</sup>	10100	11.9		2.82	7	6300	10.8
AM... 80Z BA	6	2.52	15	8500	14.5	2.52	15	9550	14.4		3.35	7	6000	12.2
AM... 90S AA	6	3.07	15(40) <sup>2)</sup>	6700	17.6	3.07	15(40) <sup>2)</sup>	7500	17.5		4	7	5300	14.6
AM... 90L BA	6	4.73	40	6300	22.8	4.73	40	7050	23.5		5	7	5000	18.0
AM... 100L AA	6	6.7	40(75) <sup>2)</sup>	5600	26.1	6.7	40(75) <sup>2)</sup>	6300	26.8		9	13	4500	21.8
AM... 100L BA	6*	9.3	40(75) <sup>2)</sup>	4750	30.6	9.3	40(75) <sup>2)</sup>	5300	31.3		12	13	3750	26.3
AM... 112M AA	6	13.2	40(75) <sup>2)</sup>	3150	35.5	13.2	40(75) <sup>2)</sup>	3500	36.2		16	13	2650	30.7
AM... 112M CA	6*	18.8	75	3000	52	18.8	75	3350	53		21	13	2500	43.7
AM... 132S ZA	6	22.3	75(150) <sup>2)</sup>	2000	55	22.3	75(150) <sup>2)</sup>	2250	56		26	30	1600	46.2
AM... 132M YA	6	29.8	75(150) <sup>2)</sup>	1800	60	29.8	75(150) <sup>2)</sup>	2000	62		34	30	1500	52
AM... 132M ZA	6	39.7	150	1700	77	39.7	150	1900	80		42	30	1400	65
AM... 160M ZA	6	106	150(250) <sup>2)</sup>	1120	119	106	150(250) <sup>2)</sup>	1260	122		108	30	900	103
AM... 160L ZA	6	139	150(250) <sup>2)</sup>	1000	140	139	150(250) <sup>2)</sup>	1120	143		141	30	850	124

\* Higher output (progressive motor)

1) Max. Number of no-load starts/hour with cyclic duration factor 50%

2) On request

Type	AMBY					AMBZ					AMS			
	J	$M_b$	$z_L$			J	$M_b$	$z_L$			J	$M_b$	$z_L$	
	$10^{-3} \text{ kgm}^2$	Nm	c/h	kg		$10^{-3} \text{ kgm}^2$	Nm	c/h	kg		$10^{-3} \text{ kgm}^2$	Nm	c/h	kg
750 min <sup>-1</sup> (8 poles)														
AM... 71Z AA	8	0.87	7.5	18000	9.1	0.87	7.5	20250	8.8		1.26	4	15000	7.8
AM... 80Z AA	8	1.94	7.5(15) <sup>2)</sup>	15000	12.2	1.94	7.5(15) <sup>2)</sup>	16750	11.9		2.82	7	11200	10.8
AM... 90S AA	8	3.07	15(40) <sup>2)</sup>	8000	17.4	3.07	15(40) <sup>2)</sup>	9000	17.3		4.00	7	6300	14.4
AM... 90L BA	8	4.54	15(40) <sup>2)</sup>	7500	21.0	4.54	15(40) <sup>2)</sup>	8400	20.9		5.5	7	6000	18.0
AM... 100L AA	8	6.7	40(75) <sup>2)</sup>	6700	26.2	6.7	40(75) <sup>2)</sup>	7550	26.9		9.3	13	5000	21.9
AM... 100L BA	8	9.3	40(75) <sup>2)</sup>	6000	31.2	9.3	40(75) <sup>2)</sup>	6750	31.9		11.9	13	4500	26.9
AM... 112M AA	8	15.7	40(75) <sup>2)</sup>	3550	44.5	15.7	40(75) <sup>2)</sup>	4000	45.2		18.3	13	3150	39.7
AM... 132S ZA	8	29.8	75(150) <sup>2)</sup>	2500	63	29.8	75(150) <sup>2)</sup>	2800	65		33.7	30	2000	55
AM... 132M ZA	8	39.7	150	2240	76	39.7	150	2500	74		42.2	30	1800	64
AM... 160M YA	8	79	150(250) <sup>2)</sup>	1320	102	79	150(250) <sup>2)</sup>	1475	104		80	30	1000	85
AM... 160M ZA	8	106	150(250) <sup>2)</sup>	1120	119	106	150(250) <sup>2)</sup>	1250	121		108	30	900	102
AM... 160L ZA	8	139	150(250) <sup>2)</sup>	1000	140	139	150(250) <sup>2)</sup>	1120	142		141	30	850	123

1) Max. Number of no-load starts/hour with cyclic duration factor 50%

2) On request

# HIGH EFFICIENCY BRAKE MOTORS – IE2

EFFICIENCY LEVEL ACCORDING TO IEC 60034-30:2008  
EFFICIENCY TESTING METHOD IEC 60034-2-1;2007

FOR MAINS VOLTAGE  
400 V - 50 HZ



Type	kW	HP	min <sup>-1</sup>	M <sub>N</sub> Nm	IE2 η			cos φ	I <sub>N</sub> 400V	I <sub>A</sub> /I <sub>N</sub>	M <sub>A</sub> /M <sub>N</sub>	M <sub>K</sub> /M <sub>N</sub>	
					50%	75%	100%						
3000 min <sup>-1</sup> (2 poles)													
AMHE ... 71Z AA	2*	0.75	1	2865	2.5	75.0	78.1	79.4	0.71	1.9	5.2	3.1	3.1
AMHE ... 80Z AA	2	0.75	1	2900	2.5	77.3	78.5	80.5	0.78	1.7	7.0	3.6	3.6
AMHE ... 80Z BA	2	1.1	1.5	2880	3.6	79.5	81.2	81.5	0.78	2.5	6.8	3.6	3.6
AMHE ... 80Z CA	2*	1.5	2	2880	5.0	80.5	82.1	82.4	0.78	3.4	7.0	3.5	3.6
AMHE ... 90S AA	2	1.5	2	2880	5.0	81.0	82.8	82.8	0.80	3.2	8.1	3.6	4.0
AMHE ... 90L CA	2	2.2	3	2860	7.3	82.5	84.0	84.0	0.85	4.4	8.5	3.5	3.7
AMHE ... 100L AA	2	3	4	2920	9.8	84.1	85.8	85.5	0.84	5.9	8.0	3.5	4.0
AMHE ... 100L BA	2*	4	5.5	2920	13.1	85.2	86.4	86.1	0.86	7.8	8.2	3.3	3.8
AMHE ... 112M AA	2	4	5.5	2940	13.0	85.5	87.0	86.8	0.88	7.6	8.0	2.9	3.3
AMHE ... 112M BA	2*	5.5	7.5	2920	18.0	85.8	87.4	87.3	0.88	10.4	8.0	3.0	3.2
AMHE ... 132S YA	2	5.5	7.5	2900	18.1	86.0	88.0	87.9	0.89	10.2	7.3	2.7	3.2
AMHE ... 132S ZA	2	7.5	10	2900	24.7	86.3	88.6	88.4	0.89	13.8	7.5	2.8	3.3
AMHE ... 132M ZA	2*	9.2	12.5	2920	30.1	88.4	89.9	90.0	0.87	16.9	8.8	3.2	3.8
AMHE ... 132M RA	2*	11	15	2920	36.0	88.1	90.0	89.7	0.90	19.8	7.5	2.8	3.4
AMHE ... 160M YA	2	11	15	2930	35.9	88.9	90.2	90.0	0.87	20.4	7.3	2.4	3.1
AMHE ... 160M ZA	2	15	20	2930	48.9	90.0	91.0	90.8	0.88	27.2	7.6	2.5	3.1
AMHE ... 160L ZA	2	18.5	25	2935	60.2	90.3	91.6	91.2	0.88	33.3	7.9	2.8	3.4
AMHE ... 160L TA	2*	22	30	2935	71.6	91.0	91.7	91.5	0.90	38.6	8.3	3.0	3.7

Type	kW	HP	min <sup>-1</sup>	M <sub>N</sub> Nm	IE2 η			cos φ	I <sub>N</sub> 400V	I <sub>A</sub> /I <sub>N</sub>	M <sub>A</sub> /M <sub>N</sub>	M <sub>K</sub> /M <sub>N</sub>	
					50%	75%	100%						
1500 min <sup>-1</sup> (4 poles)													
AMHE ... 80Z AA	4	0.75	1	1430	5.0	79.2	80.3	80.2	0.76	1.8	5.5	2.8	3.0
AMHE ... 90S AA	4	1.1	1.5	1430	7.3	81.4	82.7	82.5	0.77	2.5	6.1	4.0	4.1
AMHE ... 90L BA	4	1.5	2	1430	10.0	82.0	83.5	83.0	0.77	3.4	6.4	3.9	4.0
AMHE ... 100L AA	4	2.2	3	1450	14.5	84.0	85.3	85.1	0.74	5.1	6.0	3.2	3.4
AMHE ... 100L BA	4	3	4	1440	19.9	85.3	86.6	86.4	0.77	6.5	6.3	3.4	3.6
AMHE ... 112M AA	4	4	5.5	1450	26.3	86.0	87.3	87.1	0.78	8.5	6.1	3.1	3.3
AMHE ... 132S RA	4	5.5	7.5	1450	36.2	87.5	88.3	88.1	0.84	10.8	7.4	3.0	3.3
AMHE ... 132M TA	4	7.5	10	1450	49.4	88.5	89.4	89.2	0.85	14.4	7.4	3.0	3.3
AMHE ... 160M ZA	4	11	15	1460	71.9	89.4	90.3	90.1	0.82	22.0	6.9	2.3	2.9
AMHE ... 160L ZA	4	15	20	1460	98.1	90.6	91.2	91.0	0.84	29.0	7.4	2.5	3.1

\* Higher output (progressive motor)

For maximum friction work per stop consult us

Motors @ 460 V - 60 Hz available on request

# HIGH EFFICIENCY BRAKE MOTORS – IE2

AMHEBY SERIES – HIGH TORQUE - DC BRAKE

AMHEBZ SERIES – HIGH TORQUE - AC BRAKE

AMHES SERIES – LOW TORQUE - DC BRAKE

## IE2

Type	AMHEBY				AMHEBZ				AMHES				
	J 10 <sup>-3</sup> kgm <sup>2</sup>	M <sub>b max</sub> Nm	z <sub>L</sub> <sup>1)</sup> c/h	kg	J 10 <sup>-3</sup> kgm <sup>2</sup>	M <sub>b max</sub> Nm	z <sub>L</sub> <sup>1)</sup> c/h	kg	J 10 <sup>-3</sup> kgm <sup>2</sup>	M <sub>b</sub> Nm	z <sub>L</sub> <sup>1)</sup> c/h	kg	
3000 min <sup>-1</sup> (2 poles)													
AMHE ... 71Z AA	2*	0.63	7.5	4500	10.3	0.63	7.5	5000	10.0	1.02	3	2360	9.0
AMHE ... 80Z AA	2	0.86	7.5(15) <sup>2)</sup>	2650	15.3	0.86	7.5(15) <sup>2)</sup>	3000	15	1.75	7	1400	13.9
AMHE ... 80Z BA	2	1.07	15	2500	17.5	1.07	15	2800	17.2	1.91	7	1300	16.0
AMHE ... 80Z CA	2*	1.31	15	2650	16.2	1.31	15	3000	16.1	2.15	7	1400	13.9
AMHE ... 90S AA	2	1.69	15(40) <sup>2)</sup>	2500	22.0	1.69	15(40) <sup>2)</sup>	2800	21.9	2.61	7	1250	19.0
AMHE ... 90L CA	2	2.13	15(40) <sup>2)</sup>	2400	25.6	2.13	15(40) <sup>2)</sup>	2700	26.1	3.06	7	1120	21.7
AMHE ... 100L AA	2	3.23	40(75) <sup>2)</sup>	2060	32.2	3.23	40(75) <sup>2)</sup>	2290	32.9	5.8	13	950	27.9
AMHE ... 100L BA	2*	3.87	40(75) <sup>2)</sup>	2000	34.5	3.87	40(75) <sup>2)</sup>	2230	35.2	6.5	13	900	30.2
AMHE ... 112M AA	2	6.1	40(75) <sup>2)</sup>	950	42.9	6.1	40(75) <sup>2)</sup>	1065	44.0	8.7	13	630	36.0
AMHE ... 112M BA	2*	8.3	40(75) <sup>2)</sup>	900	45.8	8.3	40(75) <sup>2)</sup>	1000	46.5	10.9	13	600	38.3
AMHE ... 132S ZA	2	13.1	75(150) <sup>2)</sup>	670	61	13.1	75(150) <sup>2)</sup>	750	62	17.0	30	480	52.0
AMHE ... 132S TA	2	15.0	75(150) <sup>2)</sup>	550	70	15.0	75(150) <sup>2)</sup>	610	72	18.9	30	380	62.0
AMHE ... 132M ZA	2*	18.7	75(150) <sup>2)</sup>	500	77	18.7	75(150) <sup>2)</sup>	555	78	- <sup>3)</sup>	- <sup>3)</sup>	- <sup>3)</sup>	- <sup>3)</sup>
AMHE ... 132M RA	2*	18.7	75(150) <sup>2)</sup>	500	77	18.7	75(150) <sup>2)</sup>	555	78	- <sup>3)</sup>	- <sup>3)</sup>	- <sup>3)</sup>	- <sup>3)</sup>
AMHE ... 160M YA	2	35.3	150(250) <sup>2)</sup>	350	121	35.3	150(250) <sup>2)</sup>	385	123	37.2	30	315	87.0
AMHE ... 160M ZA	2	46	150(250) <sup>2)</sup>	335	135	46	150(250) <sup>2)</sup>	370	137	48	30	280	118
AMHE ... 160L ZA	2	50	150(250) <sup>2)</sup>	335	135	50	150(250) <sup>2)</sup>	370	137	52	30	280	118
AMHE ... 160L TA	2*	59	150(250) <sup>2)</sup>	335	135	59	150(250) <sup>2)</sup>	370	137	62	30	280	118

Type	AMHEBY				AMHEBZ				AMHES				
	J 10 <sup>-3</sup> kgm <sup>2</sup>	M <sub>b max</sub> Nm	z <sub>L</sub> <sup>1)</sup> c/h	kg	J 10 <sup>-3</sup> kgm <sup>2</sup>	M <sub>b max</sub> Nm	z <sub>L</sub> <sup>1)</sup> c/h	kg	J 10 <sup>-3</sup> kgm <sup>2</sup>	M <sub>b</sub> Nm	z <sub>L</sub> <sup>1)</sup> c/h	kg	
1500 min <sup>-1</sup> (4 poles)													
AMHE ... 80Z AA	4	2.6	15	5800	15.7	2.6	15	5800	15.7	3.5	7	3500	14.3
AMHE ... 90S AA	4	2.9	15(40) <sup>2)</sup>	4650	20.5	2.9	15(40) <sup>2)</sup>	5250	20.4	3.8	7	3250	17.5
AMHE ... 90L BA	4	3.7	40	4150	24.8	3.7	40	4700	25.5	4.4	7	3000	20.0
AMHE ... 100L AA	4	5.7	40(75) <sup>2)</sup>	4250	31.1	5.7	40(75) <sup>2)</sup>	4800	31.8	8.3	13	2350	26.8
AMHE ... 100L BA	4	7.2	40(75) <sup>2)</sup>	4050	33.6	7.24	40(75) <sup>2)</sup>	4550	34.3	9.3	13	2000	29.3
AMHE ... 112M AA	4	13.0	75	2370	44.7	13.0	75	2650	46.1	15.1	13	1410	36.5
AMHE ... 132S RA	4	25.4	75(150) <sup>2)</sup>	1800	69	25.4	75(150) <sup>2)</sup>	2000	70	29.2	30	1000	60
AMHE ... 132M TA	4	33.4	75(150) <sup>2)</sup>	1500	87	33.4	75(150) <sup>2)</sup>	1690	89	35.9	30	800	74
AMHE ... 160M ZA	4	90	150(250) <sup>2)</sup>	600	133	90	150(250) <sup>2)</sup>	675	136	92	30	500	117
AMHE ... 160L ZA	4	102	150(250) <sup>2)</sup>	585	143	102	150(250) <sup>2)</sup>	655	145	105	30	480	126

\* Higher output (progressive motor)

1) Max. Number of no-load starts/hour with cyclic duration factor 50%

2) On request