

	<h1>NORM.STM</h1>	NORM0265	
		PAG.1/48	<b>R2</b>
<i>Redatto/Disegnato da</i> Enrico BARONI <i>Controllato da</i> Davide FABBRI	<i>DESCRIZIONE</i>  <h2>GENERALE COMPONENTI EX</h2>	<i>Data, 10/06/08</i>	
		Rev. 1	23/06/2011
		Rev. 2	23/02/2012

IN QUESTA NORMATIVA SONO CONTENUTE TUTTE LE ISTRUZIONI RELATIVE ALLE MODALITÀ DI RICHIESTA DELLE PARTI DI RICAMBIO DEI RIDUTTORI EX STM.  
 LA LISTA PARTI DI RICAMBIO E' FORNITA NELLE LINGUE:

- Italiano
- Inglese
- Francese
- Tedesco
- Spagnolo



**PARTI DI RICAMBIO  
SPARE LISTS**

**NORM0265-R2**  
Del 23/02/2012  
Pag.1 di 43

STM spa  
VIA DEL MACCABRECCIA , 39  
40012 - CALDERARA DI RENO (BO)  
ITALY  
E-mail: [stm@stmspa.com](mailto:stm@stmspa.com)  
TEL ++ 39.051.6467111 FAX ++ 39.051.6466178

EX

EX



**LISTA PARTI DI RICAMBIO**



**SPARE LISTS**

In questo documento sono contenute tutte le istruzioni relative alle modalità di richiesta delle Parti di Ricambio dei Riduttori EX STM.

*This document is about the procedure to request spare parts of EX STM.*

**MODALITA' OPERATIVE**

**GENERALITA'**

La Tab. RPR indica i dati che è indispensabile fornire in fase di richiesta Parti di Ricambio per poter effettuare una corretta identificazione del prodotto e di conseguenza una sollecita risposta alla richiesta stessa.

In particolare si richiede:

- 1) Compilare il modulo "Richiesta Parti di Ricambio" riportato in Tab. RPR;
- 2) Inviarlo via Fax al nr. sopra indicato;
- 3) Attendere Fax di conferma da parte della STM S.p.a.

**PROCEDURE :**

*The chart RPR shows the data needed when requesting spare parts in order to enable a correct product identification and consequently a quick reply to the inquiry. Please provide :*

- 1) *The form " Spare part request " shown in Tab. RPR duly filled in.*
- 2) *Fax it to the number above given.*
- 3) *Wait for the return confirmatiopn fax by STM S.p.a*

**MODALITA' COMPILAZIONE MODULO**

Dalla targhetta applicata sul prodotto STM trascrivere:

- Tipo;
- O.L./W.O.

**HOW TO FILL THE FORM IN :**

*From the nameplate on the STM product copy on the form :*

- Product type*
- O.L./W.O.*

Dalla Tavole ricavare:

- Ref. del componente da richiedere;
- Descrizione del componente da richiedere

*From the charts define :*

- *Reference of the spare part to request*
- *Full description of the spare part to request*

TABELLA AGGIORNAMENTI APPORTATI NUOVA REVISIONE.

			Aggiornamenti apportati	News	
Paragrafo Chapter	Pagina Page	Indice Revisione Aggiornamenti	Descrizione	Description	
	2-3	2.0	Aggiornata la designazione della Tav. 0		
	35	2.0	Aggiunto componente 39 nella tavola Tav. XIII		
	33-34	2.0	Aggiunta la Tavola Tav.XII - EXB		



**PARTI DI RICAMBIO  
SPARE LISTS**

**NORM0265-R2**  
Del 23/02/2012  
Pag.2 di 43

STM spa  
VIA DEL MACCABRECCIA, 39  
40012 - CALDERARA DI RENO (BO)  
ITALY  
E-mail: [stm@stmspa.com](mailto:stm@stmspa.com)  
TEL ++ 39 051.646711 FAX ++ 39 051.6466178

EX

EX

**TAVOLA 0 - EX 10 - 20 - 25 - 30 - 40 - 50 - 70 - 80 - 100**

Tav. I	Uscite-Outputs - R-L-M-P-FB
Tav. II	Uscite-Outputs - T
Tav. III	Uscite-Output - FP-FS
Tav. IV	Uscite-Output -FCB
Tav. V	---
Tav. VI	---
Tav. VII	Uscite-Output - V1N-V1I..
Tav. VIII	---
Tav. IX	---
Tav. X	Stadi-Stages - 1-2-3-4
Tav. XI	Combinazione Stadi -Assembly Stages
Tav. XII	Entrate-Inputs - EXB
Tav. XIII	Entrate-Inputs - Z1A1...
Tav. XIV	---
Tav. XV	Entrate-Inputs - EXV-EXC-EXR...
Tav. XVI	Entrate-Inputs - EU
Tav. XVII	Entrate-Inputs - ECE-ECR
Tav. XVIII	Entrate-Inputs - I - IEC
Tav. XIX	Accessori-Accessories

**Designazione Catalogo CT 26-Sezione**  
Designation Catalogue CT 26-Part

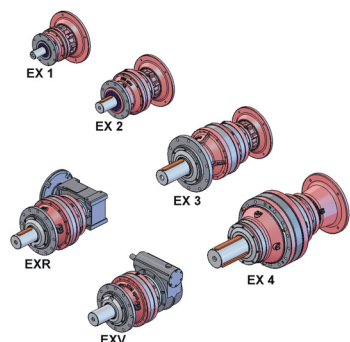

EXR	50	1	708	RN1	63.4	Z1A1	100B5
CO	SIZE	NOR	CG	OV OS	IR	TBZ SIZEBZ STBZ ABZ	IV IS
1	2	3	4	5 6	7	8a 8c 8b 8d	9 10

**10-20-25-30-40-50-70-80-100**

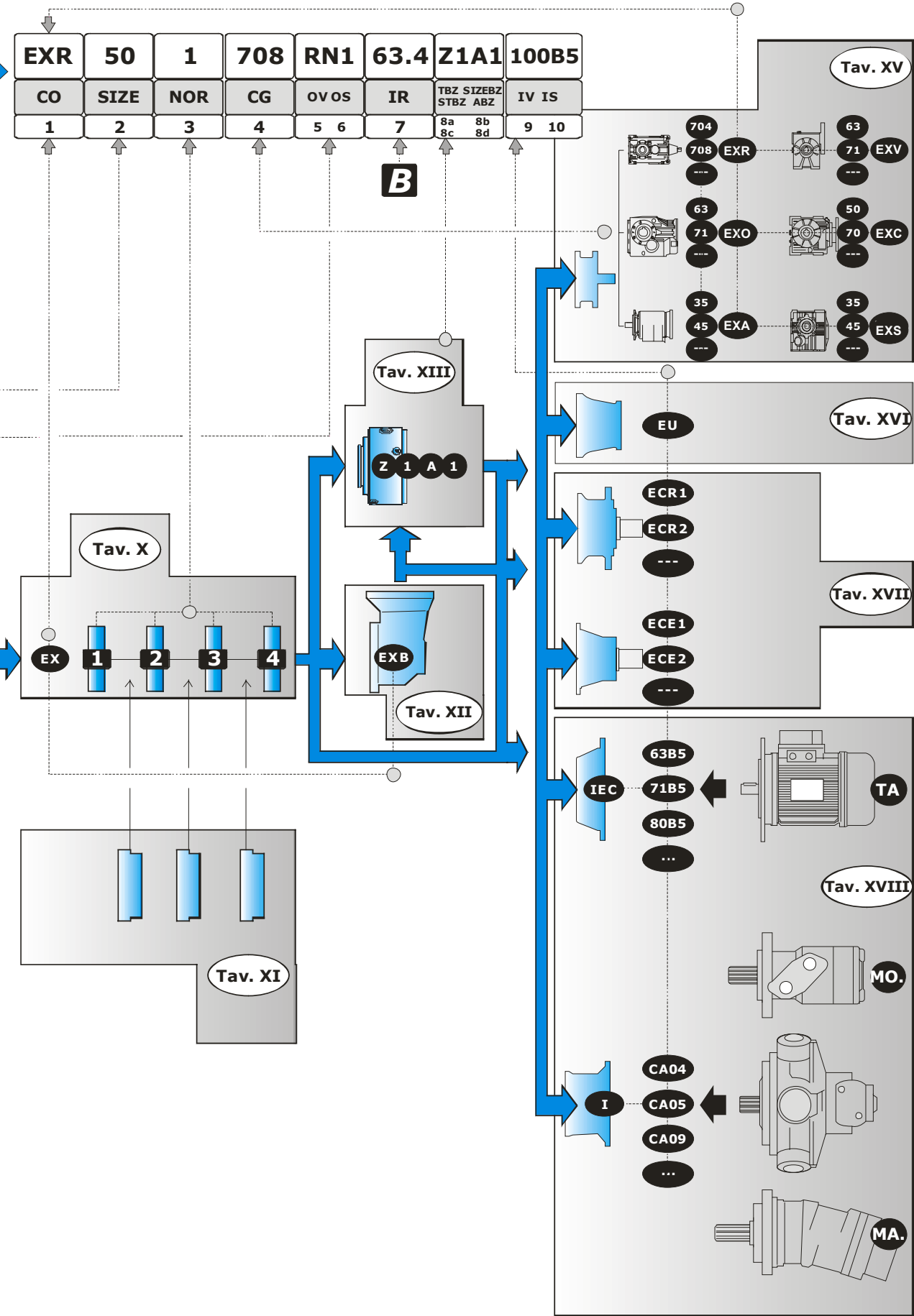
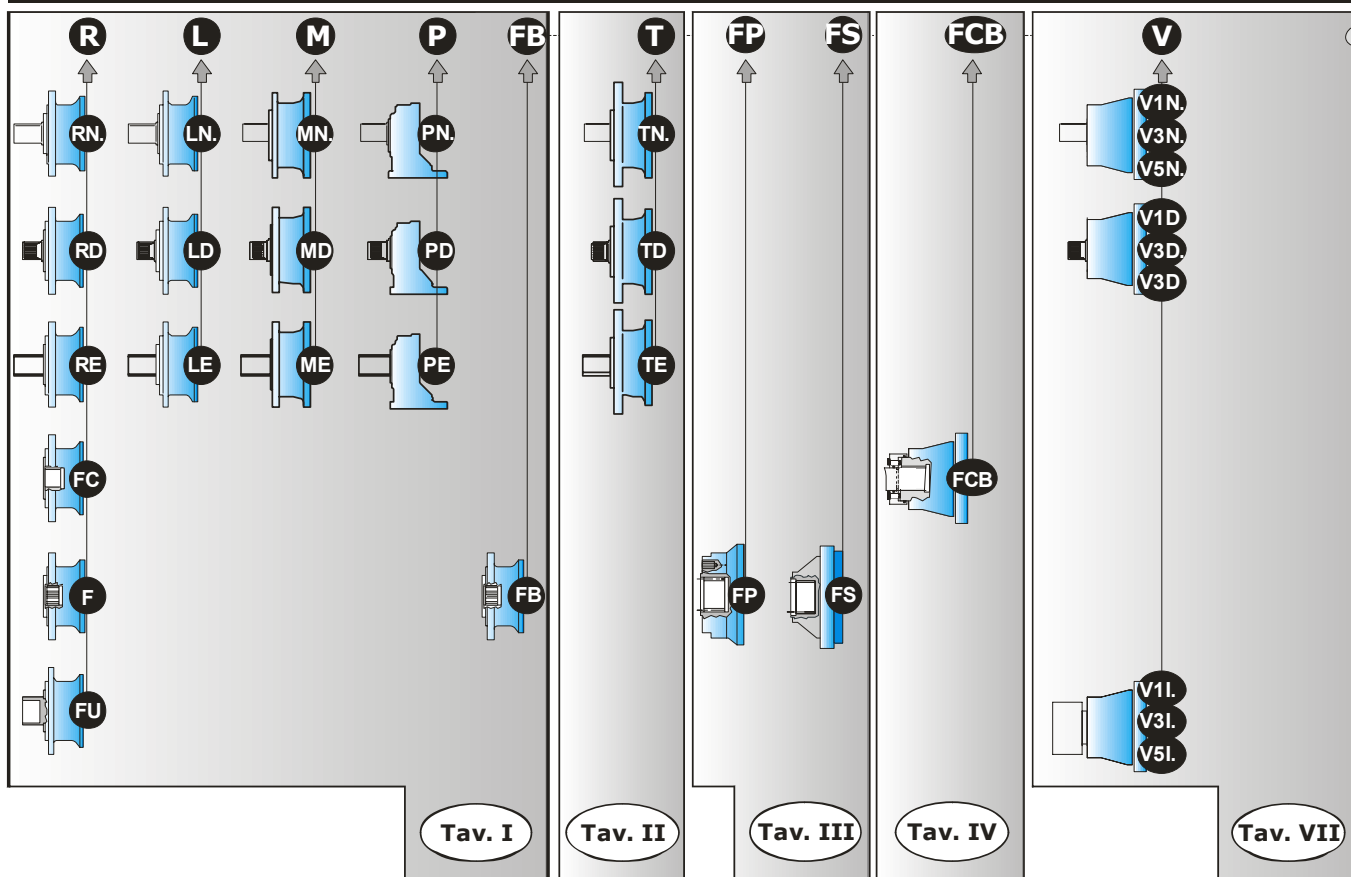

**Accessori Catalogo CT 26-Sezione**  
Accessories Catalogue CT 26-Sezione



**PARTI DI RICAMBIO  
SPARE LISTS**

**NORM0265-R2**  
Del 23/02/2012  
Pag.3 di 43

STM spa  
VIA DEL MACCABRECCIA, 39  
40012 - CALDERARA DI RENO (BO)  
ITALY  
E-mail: [stm@stmspa.com](mailto:stm@stmspa.com)  
TEL ++ 39 051.646711 FAX ++ 39 051.6466178

EX

EX

**TAVOLA 0 - EX 150 - 180 - 250 - 280 - 300 - 420 - 650 - 850**

Tav. I	Uscite-Outputs - R-P
Tav. II	Uscite-Outputs - T
Tav. III	Uscite-Output - FS
Tav. IV	Uscite-Output -FCB
Tav. V	Uscite-Output -H-PH-X-PX
Tav. VI	Uscite-Output -S-PS-SB-PSB
Tav. VII	Uscite-Output - V1N-V1I..
Tav. VIII	---
Tav. IX	---
Tav. X	Stadi-Stages - 1-2-3-4
Tav. XI	Combinazione Stadi -Assembly Stages
Tav. XII	Entrate-Inputs - EXB
Tav. XIII	Entrate-Inputs - Z1A1...
Tav. XIV	---
Tav. XV	Entrate-Inputs - EXV-EXC-EXR...
Tav. XVI	Entrate-Inputs - EU
Tav. XVII	Entrate-Inputs - ECE-ECR
Tav. XVIII	Entrate-Inputs - I - IEC
Tav. XIX	Accessori-Accessories

**Designazione Catalogo CT 26-Sezione**  
Designation Catalogue CT 26-Part

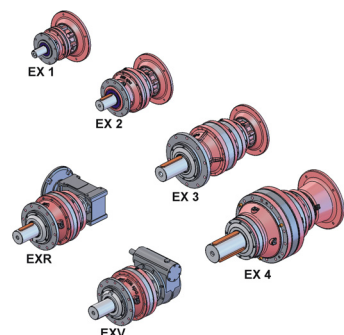

EXR	50	1	708	RN1	63.4	Z1A1	100B5
CO	SIZE	NOR	CG	OV OS	IR	TBZ SIZEBZ STBZ ABZ	IV IS
1	2	3	4	5 6	7	8a 8c 8b 8d	9 10

**150-180-250-280-300-420-650-850**

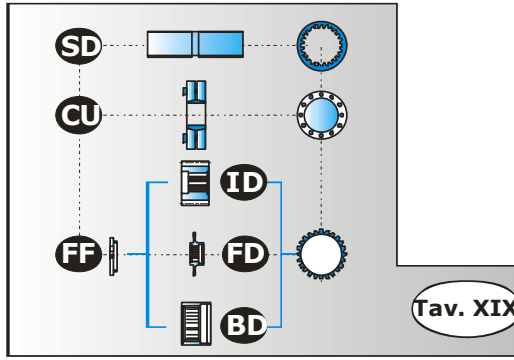
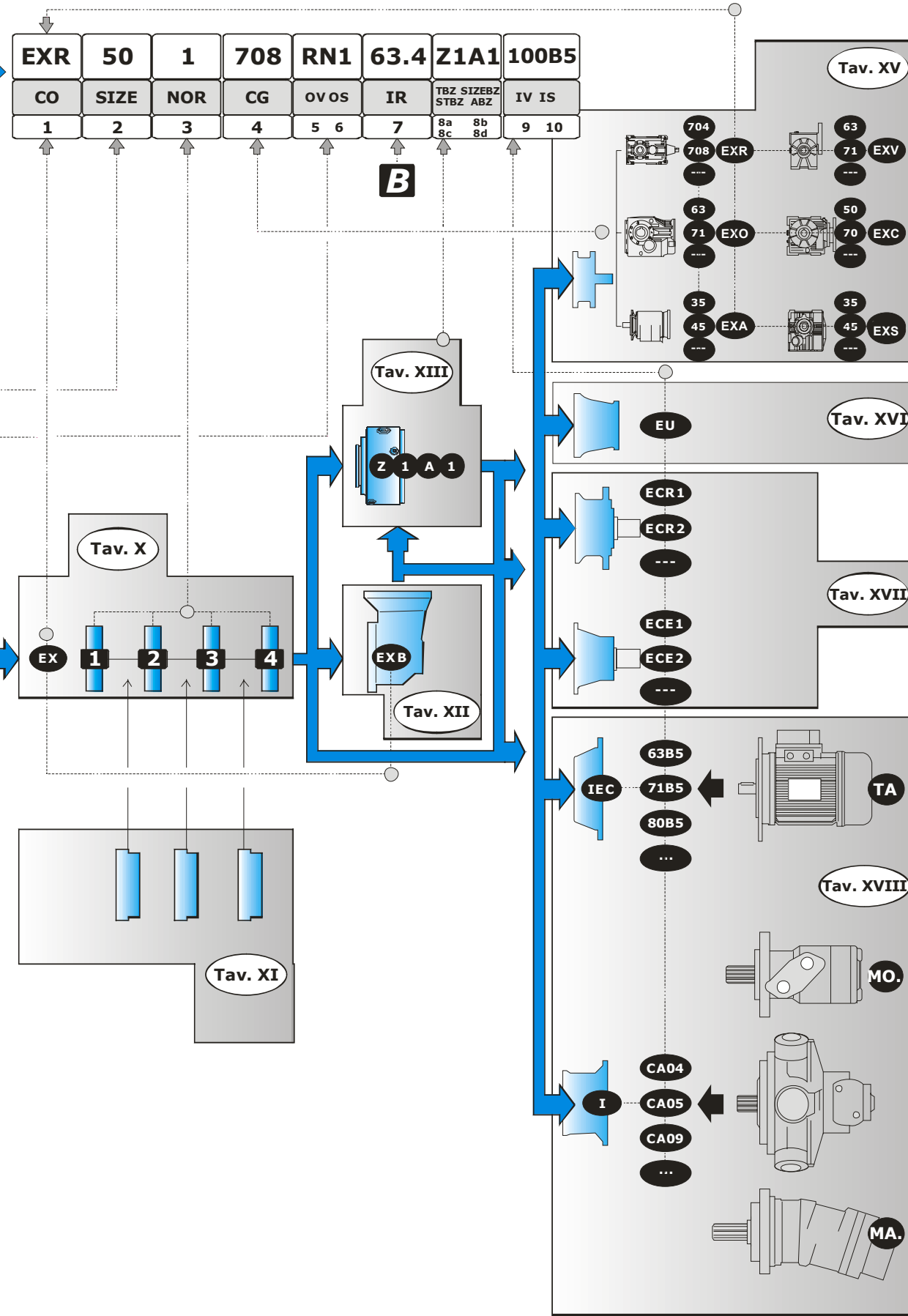
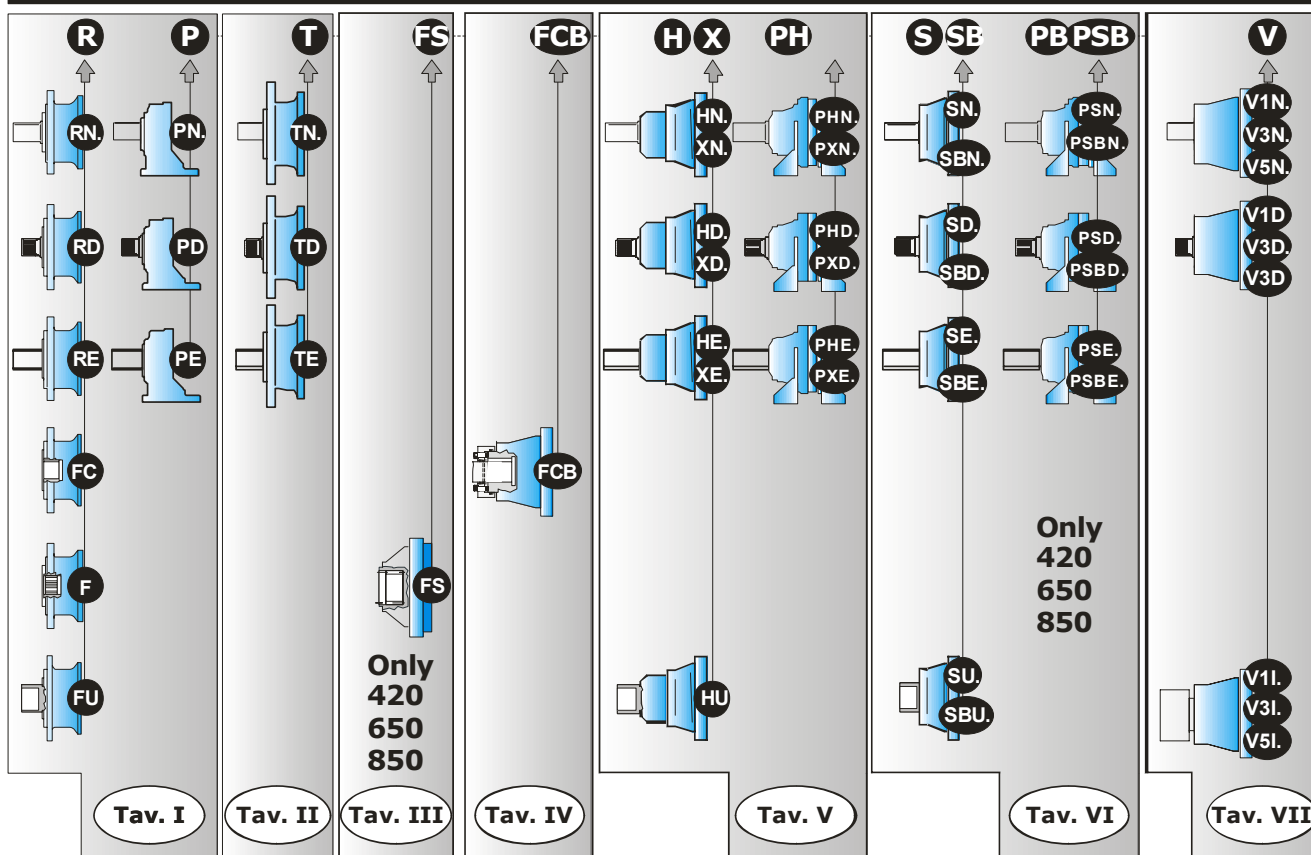

**Accessori Catalogo CT 26-Sezione**  
Accessories Catalogue CT 26-Sezione

EX

EX

**TAVOLA I**

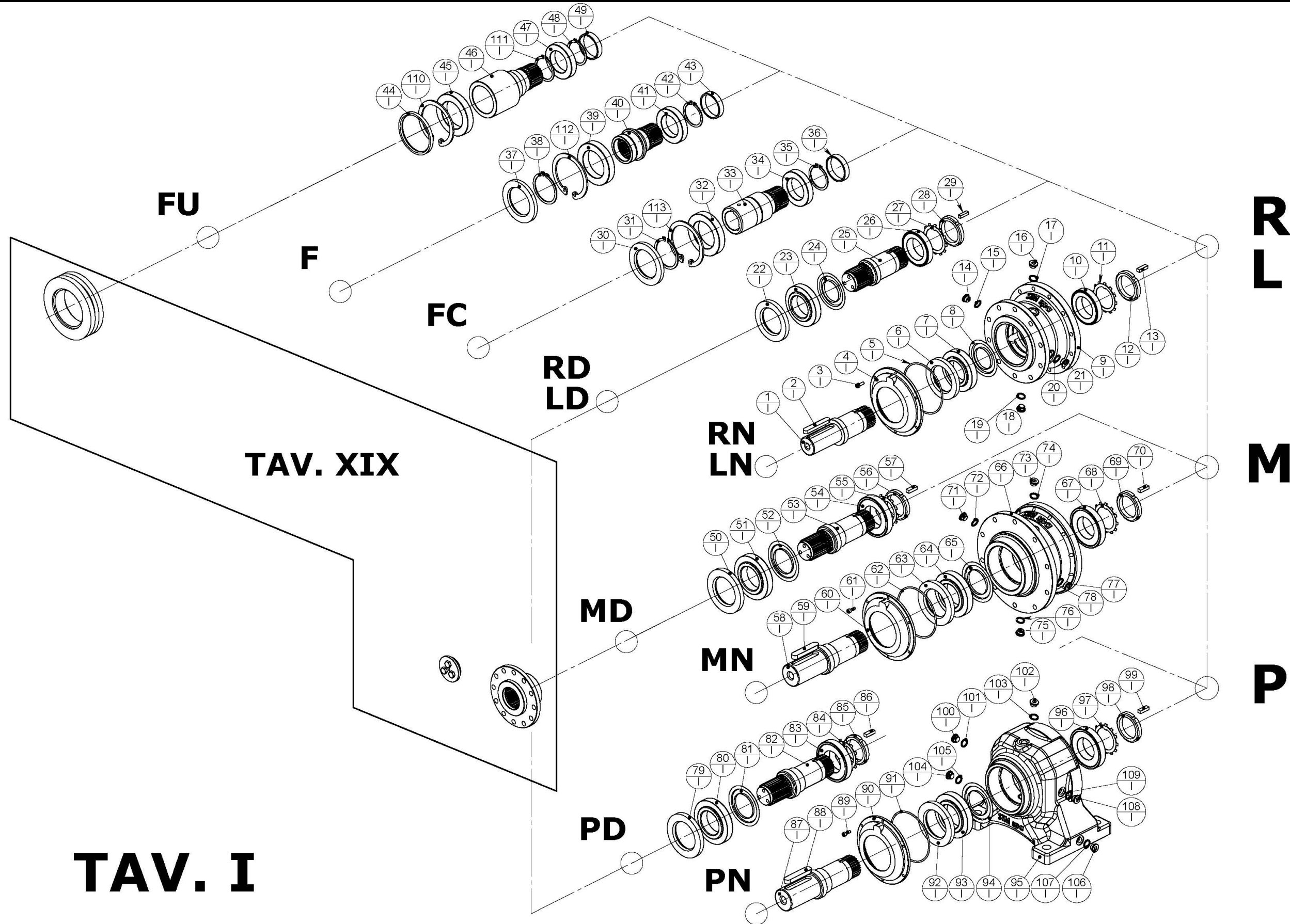



**PARTI DI RICAMBIO  
SPARE LISTS**

**NORM0265-R2**  
Del 23/02/2012  
Pag.5 di 43

STM spa  
VIA DEL MACCABRECCIA , 39  
40012 - CALDERARA DI RENO (BO)  
ITALY  
E-mail: [stm@stmspa.com](mailto:stm@stmspa.com)  
TEL ++ 39.051.646711 FAX ++ 39.051.6466178

EX

-

EX

**TAVOLA I**

ITEM	TAVOLA	DESCRIZIONE ( I )	DESCRIPTION ( GB )	DESIGNATION ( F )	BEZEICHNUNG ( D )	DENOMINACION ( E )	NOTE
<b>RN</b>							
1	I	ALBERO USCITA	OUTPUT SHAFT	ARBRE SORTIE	ABTRIEBSWELLE	EJE SALIDA	
2	I	LINGUETTA	KEY	CLAVETTE	PASSFEDER	CHAVETA	
3	I	VITE DI FISSAGGIO	SCREW	VIS	BEFESTIGUNGSSCHRAUBE	TORNILLO DE SUJECION	
4	I	COPERCHIO USCITA	OUTPUT COVER				
5	I	GUARN OR					
6	I	ANELLO DI TENUTA	RUBBER SEAL RING	BASQUE D'ÉTANCHÉITÉ	DICHTUNGSRING		
7	I	CUSCINETTO	BEARING	ROULEMENT	WÄZLAGER	RODAMIENTO	
8	I	ANELLO NILOS	NILOS RING				
9	I	SUPPORTO ALBERO USCITA	ECE SHAFT OUTPUT SUPPORT				
10	I	CUSCINETTO	BEARING	ROULEMENT	WÄZLAGER	RODAMIENTO	
11	I	ROSETTA SICUREZZA					
12	I	GHIERA DI REGOLAZIONE	ADJUSTMENT GROOVE NUT	FRETTE DE REGLAGE	EINSTELL-NUTMUTTER	TUERCA ACANALADA	
13	I	LINGUETTA	KEY				
14	I	TAPPO	PLUG	BOUCHON	VERSCHLUSS	TAPON	
15	I	GUARNIZIONE	GASKET	JOINT PAPIER	DICHTUNG	JUNTA	
16	I	TAPPO	PLUG	BOUCHON	VERSCHLUSS	TAPON	
17	I	GUARNIZIONE	GASKET	JOINT PAPIER	DICHTUNG	JUNTA	
18	I	TAPPO	PLUG	BOUCHON	VERSCHLUSS	TAPON	
19	I	GUARNIZIONE	GASKET	JOINT PAPIER	DICHTUNG	JUNTA	
20	I	GUARNIZIONE	GASKET	JOINT PAPIER	DICHTUNG	JUNTA	
21	I	TAPPO	PLUG	BOUCHON	VERSCHLUSS	TAPON	
<b>RD</b>							
22	I	ANELLO DI TENUTA	RUBBER SEAL RING	BASQUE D'ÉTANCHÉITÉ	DICHTUNGSRING		
23	I	CUSCINETTO	BEARING	ROULEMENT	WÄZLAGER	RODAMIENTO	
24	I	ANELLO NILOS	NILOS RING				
25	I	ALBERO USCITA	OUTPUT SHAFT	ARBRE SORTIE	ABTRIEBSWELLE	EJE SALIDA	
26	I	CUSCINETTO	BEARING	ROULEMENT	WÄZLAGER	RODAMIENTO	
27	I	ROSETTA SICUREZZA					
28	I	GHIERA DI REGOLAZIONE	ADJUSTMENT GROOVE NUT	FRETTE DE REGLAGE	EINSTELL-NUTMUTTER	TUERCA ACANALADA	
29	I	LINGUETTA	KEY				
<b>FC</b>							
30	I	ANELLO DI TENUTA	RUBBER SEAL RING	BASQUE D'ÉTANCHÉITÉ	DICHTUNGSRING		
31	I	SEEGER	CIRCLIP	CIRCLIP	SICHERUNGSRING	SEEGER	
32	I	CUSCINETTO	BEARING	ROULEMENT	WÄZLAGER	RODAMIENTO	
33	I	ALBERO USCITA	OUTPUT SHAFT	ARBRE SORTIE	ABTRIEBSWELLE	EJE SALIDA	
34	I	CUSCINETTO	BEARING	ROULEMENT	WÄZLAGER	RODAMIENTO	
35	I	SEEGER	CIRCLIP	CIRCLIP	SICHERUNGSRING	SEEGER	
36	I	DISTANZIALE	SPACER				
113	I	SEEGER	CIRCLIP	CIRCLIP	SICHERUNGSRING	SEEGER	
<b>F</b>							
37	I	ANELLO DI TENUTA	RUBBER SEAL RING	BASQUE D'ÉTANCHÉITÉ	DICHTUNGSRING		
38	I	SEEGER	CIRCLIP	CIRCLIP	SICHERUNGSRING	SEEGER	
39	I	CUSCINETTO	BEARING	ROULEMENT	WÄZLAGER	RODAMIENTO	
40	I	ALBERO USCITA	OUTPUT SHAFT	ARBRE SORTIE	ABTRIEBSWELLE	EJE SALIDA	
41	I	CUSCINETTO	BEARING	ROULEMENT	WÄZLAGER	RODAMIENTO	
42	I	SEEGER	CIRCLIP	CIRCLIP	SICHERUNGSRING	SEEGER	



**PARTI DI RICAMBIO  
SPARE LISTS**

**NORM0265-R2**  
Del 23/02/2012  
Pag. 6 di 43

STM spa  
VIA DEL MACCABRECCIA, 39  
40012 - CALDERARA DI RENO (BO)  
ITALY  
E-mail: [stm@stmspa.com](mailto:stm@stmspa.com)  
TEL ++ 39 051.646711 FAX ++ 39 051.6466178

EX

EX

**TAVOLA I**

ITEM	TAVOLA	DESCRIZIONE ( I )	DESCRIPTION ( GB )	DESIGNATION ( F )	BEZEICHNUNG ( D )	DENOMINACION ( E )	NOTE
43	I	DISTANZIALE	SPACER				
112	I	SEEGER	CIRCLIP	CIRCLIP	SICHERUNGSRING	SEEGER	
<b>FU</b>							
44	I	ANELLO DI TENUTA	RUBBER SEAL RING	BASQUE D'ÉTANCHÉITÉ	DICHTUNGSRING		
45	I	CUSCINETTO	BEARING	ROULEMENT	WÄZLAGER	RODAMIENTO	
46	I	ALBERO USCITA	OUTPUT SHAFT	ARBRE SORTIE	ABTRIEBSWELLE	EJE SALIDA	
47	I	CUSCINETTO	BEARING	ROULEMENT	WÄZLAGER	RODAMIENTO	
48	I	SEEGER	CIRCLIP	CIRCLIP	SICHERUNGSRING	SEEGER	
49	I	DISTANZIALE	SPACER				
110	I	SEEGER	CIRCLIP	CIRCLIP	SICHERUNGSRING	SEEGER	
111	I	SEEGER	CIRCLIP	CIRCLIP	SICHERUNGSRING	SEEGER	
<b>MD</b>							
50	I	ANELLO DI TENUTA	RUBBER SEAL RING	BASQUE D'ÉTANCHÉITÉ	DICHTUNGSRING		
51	I	CUSCINETTO	BEARING	ROULEMENT	WÄZLAGER	RODAMIENTO	
52	I	ANELLO NILOS	NILOS RING				
53	I	ALBERO USCITA	OUTPUT SHAFT	ARBRE SORTIE	ABTRIEBSWELLE	EJE SALIDA	
54	I	CUSCINETTO	BEARING	ROULEMENT	WÄZLAGER	RODAMIENTO	
55	I	ROSETTA SICUREZZA					
56	I	GHIERA DI REGOLAZIONE	ADJUSTMENT GROOVE NUT	FRETTE DE REGLAGE	EINSTELL-NUTMUTTER	TUERCA ACANALADA	
57	I	LINGUETTA	KEY				
<b>MN</b>							
58	I	ALBERO USCITA	OUTPUT SHAFT	ARBRE SORTIE	ABTRIEBSWELLE	EJE SALIDA	
59	I	LINGUETTA	KEY	CLAVETTE	PASSFEDER	CHAVETA	
60	I	COPERCHIO USCITA	OUTPUT COVER				
61	I	VITE DI FISSAGGIO	SCREW	VIS	BEFESTIGUNGSSCHRAUBE	TORNILLO DE SUJECION	
62	I	GUARN OR					
63	I	ANELLO DI TENUTA	RUBBER SEAL RING	BASQUE D'ÉTANCHÉITÉ	DICHTUNGSRING		
64	I	CUSCINETTO	BEARING	ROULEMENT	WÄZLAGER	RODAMIENTO	
65	I	ANELLO NILOS	NILOS RING				
66	I	SUPPORTO ALBERO USCITA	ECE SHAFT OUTPUT SUPPORT				
67	I	CUSCINETTO	BEARING	ROULEMENT	WÄZLAGER	RODAMIENTO	
68	I	ROSETTA SICUREZZA					
69	I	GHIERA DI REGOLAZIONE	ADJUSTMENT GROOVE NUT	FRETTE DE REGLAGE	EINSTELL-NUTMUTTER	TUERCA ACANALADA	
70	I	LINGUETTA	KEY				
71	I	TAPPO	PLUG	BOUCHON	VERSCHLUSS	TAPON	
72	I	GUARNIZIONE	GASKET	JOINT PAPIER	DICHTUNG	JUNTA	
73	I	TAPPO	PLUG	BOUCHON	VERSCHLUSS	TAPON	
74	I	GUARNIZIONE	GASKET	JOINT PAPIER	DICHTUNG	JUNTA	
75	I	TAPPO	PLUG	BOUCHON	VERSCHLUSS	TAPON	
76	I	GUARNIZIONE	GASKET	JOINT PAPIER	DICHTUNG	JUNTA	
77	I	TAPPO	PLUG	BOUCHON	VERSCHLUSS	TAPON	
78	I	GUARNIZIONE	GASKET	JOINT PAPIER	DICHTUNG	JUNTA	
<b>PD</b>							
79	I	ANELLO DI TENUTA	RUBBER SEAL RING	BASQUE D'ÉTANCHÉITÉ	DICHTUNGSRING		
80	I	CUSCINETTO	BEARING	ROULEMENT	WÄZLAGER	RODAMIENTO	
81	I	ANELLO NILOS	NILOS RING				
82	I	ALBERO USCITA	OUTPUT SHAFT	ARBRE SORTIE	ABTRIEBSWELLE	EJE SALIDA	
83	I	CUSCINETTO	BEARING	ROULEMENT	WÄZLAGER	RODAMIENTO	



**PARTI DI RICAMBIO  
SPARE LISTS**

**NORM0265-R2**  
Del 23/02/2012  
Pag.7 di 43

STM spa  
VIA DEL MACCABRECCIA , 39  
40012 - CALDERARA DI RENO (BO)  
ITALY  
E-mail: [stm@stmspa.com](mailto:stm@stmspa.com)  
TEL ++ 39 051.646711 FAX ++ 39 051.6466178

EX

-

EX

**TAVOLA I**

ITEM	TAVOLA	DESCRIZIONE ( I )	DESCRIPTION ( GB )	DESIGNATION ( F )	BEZEICHNUNG ( D )	DENOMINACION ( E )	NOTE
84	I	ROSETTA SICUREZZA					
85	I	GHIERA DI REGOLAZIONE	ADJUSTMENT GROOVE NUT	FRETTE DE REGLAGE	EINSTELL-NUTMUTTER	TUERCA ACANALADA	
86	I	LINGUETTA	KEY				

**PN**

87	I	ALBERO USCITA	OUTPUT SHAFT	ARBRE SORTIE	ABTRIEBSWELLE	EJE SALIDA	
88	I	LINGUETTA	KEY	CLAVETTE	PASSFEDER	CHAVETA	
89	I	VITE DI FISSAGGIO	SCREW	VIS	BEFESTIGUNGSSCHRAUBE	TORNILLO DE SUJECION	
90	I	COPERCHIO USCITA	OUTPUT COVER				
91	I	GUARN OR					
92	I	ANELLO DI TENUTA	RUBBER SEAL RING	BASQUE D'ÉTANCHÉITÉ	DICHTUNGSRING		
93	I	CUSCINETTO	BEARING	ROULEMENT	WÄLZLAGER	RODAMIENTO	
94	I	ANELLO NILOS	NILOS RING				
95	I	SUPPORTO ALBERO USCITA	ECE SHAFT OUTPUT SUPPORT				
96	I	CUSCINETTO	BEARING	ROULEMENT	WÄLZLAGER	RODAMIENTO	
97	I	ROSETTA SICUREZZA					
98	I	GHIERA DI REGOLAZIONE	ADJUSTMENT GROOVE NUT	FRETTE DE REGLAGE	EINSTELL-NUTMUTTER	TUERCA ACANALADA	
99	I	LINGUETTA	KEY				
100	I	TAPPO	PLUG	BOUCHON	VERSCHLUSS	TAPON	
101	I	GUARNIZIONE	GASKET	JOINT PAPIER	DICHTUNG	JUNTA	
102	I	TAPPO	PLUG	BOUCHON	VERSCHLUSS	TAPON	
103	I	GUARNIZIONE	GASKET	JOINT PAPIER	DICHTUNG	JUNTA	
104	I	TAPPO	PLUG	BOUCHON	VERSCHLUSS	TAPON	
105	I	GUARNIZIONE	GASKET	JOINT PAPIER	DICHTUNG	JUNTA	
106	I	TAPPO	PLUG	BOUCHON	VERSCHLUSS	TAPON	
107	I	GUARNIZIONE	GASKET	JOINT PAPIER	DICHTUNG	JUNTA	
108	I	TAPPO	PLUG	BOUCHON	VERSCHLUSS	TAPON	
109	I	GUARNIZIONE	GASKET	JOINT PAPIER	DICHTUNG	JUNTA	
110	I	SEEGER	CIRCLIP	CIRCLIP	SICHERUNGSRING	SEEGER	
111	I	SEEGER	CIRCLIP	CIRCLIP	SICHERUNGSRING	SEEGER	





EX

EX

**TAVOLA II**

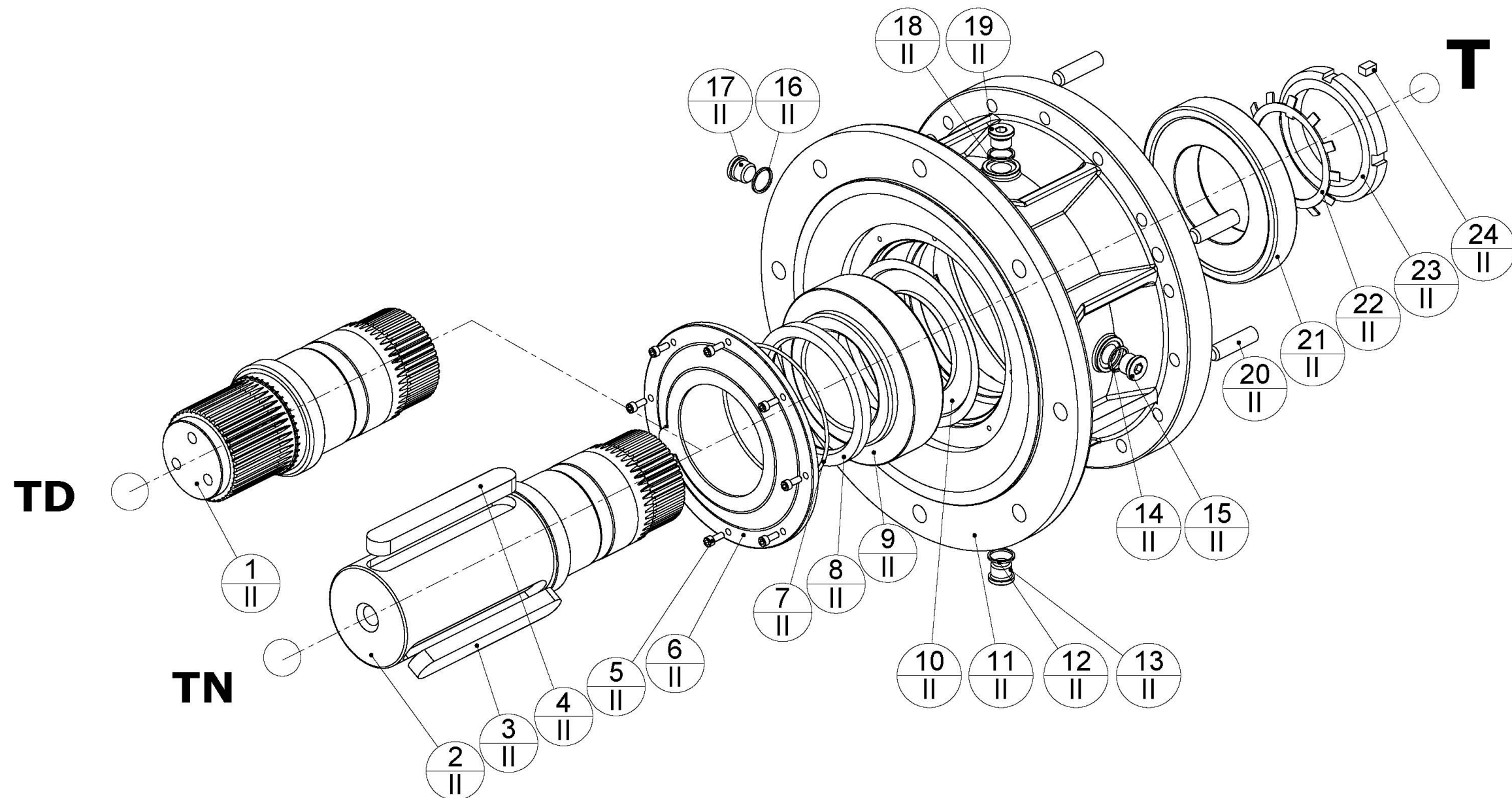

**TAV. II**



**PARTI DI RICAMBIO  
SPARE LISTS**

**NORM0265-R2**  
Del 23/02/2012  
Pag.9 di 43

STM spa  
VIA DEL MACCABRECCIA , 39  
40012 - CALDERARA DI RENO (BO)  
ITALY  
E-mail: [stm@stmspa.com](mailto:stm@stmspa.com)  
TEL ++ 39 051.646711 FAX ++ 39 051.6466178

EX

-

EX

**TAVOLA II**

ITEM	TAVOLA	DESCRIZIONE ( I )	DESCRIPTION ( GB )	DESIGNATION ( F )	BEZEICHNUNG ( D )	DENOMINACION ( E )	NOTE
<b>T</b>							
1	II	ALBERO USCITA	OUTPUT SHAFT	ARBRE SORTIE	ABTRIEBSWELLE	EJE SALIDA	
2	II	ALBERO USCITA	OUTPUT SHAFT	ARBRE SORTIE	ABTRIEBSWELLE	EJE SALIDA	
3	II	LINGUETTA	KEY	CLAVETTE	PASSFEDER	CHAVETA	
4	II	LINGUETTA	KEY	CLAVETTE	PASSFEDER	CHAVETA	
5	II	VITE DI FISSAGGIO	SCREW	VIS	BEFESTIGUNGSSCHRAUBE	TORNILLO DE SUJECION	
6	II	COPERCHIO USCITA	OUTPUT COVER				
7	II	GUARN OR					
8	II	ANELLO DI TENUTA	RUBBER SEAL RING	BASQUE D'ÉTANCHÉITÉ	DICHTUNGSRING		
9	II	CUSCINETTO	BEARING	ROULEMENT	WÄZLAGER		
10	II	ANELLO NILOS	NILOS RING				
11	II	SUPPORTO ALBERO USCITA	ECE SHAFT OUTPUT SUPPORT				
12	II	GUARNIZIONE	GASKET	JOINT PAPIER	DICHTUNG	JUNTA	
13	II	TAPPO	PLUG	BOUCHON	VERSCHLUSS	TAPON	
14	II	GUARNIZIONE	GASKET	JOINT PAPIER	DICHTUNG	JUNTA	
15	II	TAPPO	PLUG	BOUCHON	VERSCHLUSS	TAPON	
16	II	GUARNIZIONE	GASKET	JOINT PAPIER	DICHTUNG	JUNTA	
17	II	TAPPO	PLUG	BOUCHON	VERSCHLUSS	TAPON	
18	II	GUARNIZIONE	GASKET	JOINT PAPIER	DICHTUNG	JUNTA	
19	II	TAPPO	PLUG	BOUCHON	VERSCHLUSS	TAPON	
20	II	SPINA	PIN	GOUPILLE	STIFT	ESPINA	
21	II	CUSCINETTO	BEARING	ROULEMENT	WÄZLAGER		
22	II	ROSETTA SICUREZZA					
23	II	GHIERA DI REGOLAZIONE	ADJUSTMENT GROOVE NUT	FRETTE DE REGLAGE	EINSTELL-NUTMUTTER	TUERCA ACANALADA	
24	II	LINGUETTA	KEY				

### TAVOLA III

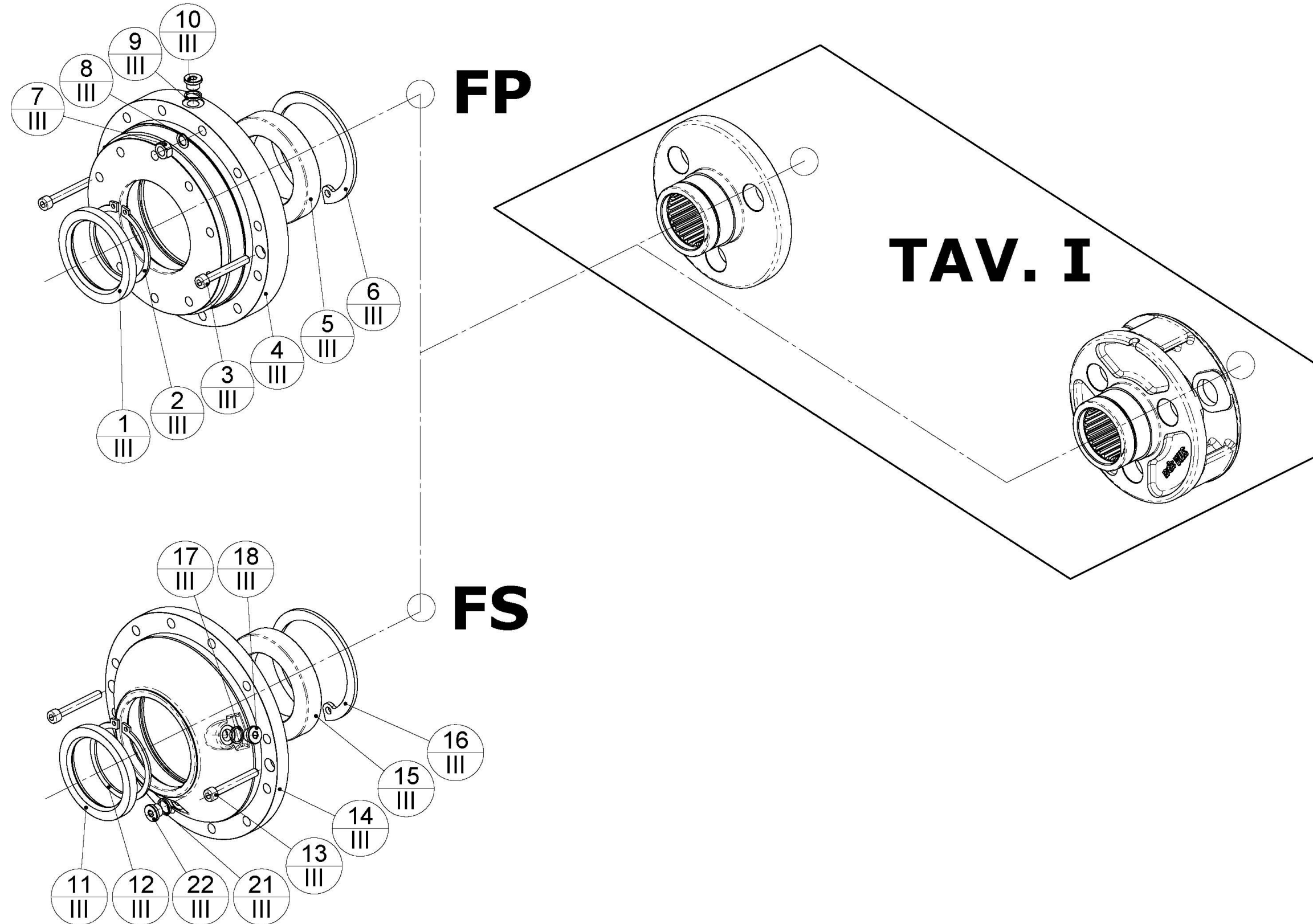

### TAV. III



**PARTI DI RICAMBIO  
SPARE LISTS**

**NORM0265-R2**

Del 23/02/2012

Pag.11 di 43

STM spa  
VIA DEL MACCABRECCIA , 39  
40012 - CALDERARA DI RENO (BO)  
ITALY  
E-mail: [stm@stmspa.com](mailto:stm@stmspa.com)  
TEL ++ 39.051.646711 FAX ++ 39.051.6466178

EX

-

EX

**TAVOLA III**

ITEM	TAVOLA	DESCRIZIONE ( I )	DESCRIPTION ( GB )	DESIGNATION ( F )	BEZEICHNUNG ( D )	DENOMINACION ( E )	NOTE
<b>FP</b>							
1	III	ANELLO DI TENUTA	RUBBER SEAL RING	BASQUE D'ÉTANCHÉITÉ	DICHTUNGSRING		
2	III	SEEGER	CIRCLIP	CIRCLIP	SICHERUNGSRING	SEEGER	
3	III	VITE DI FISSAGGIO	SCREW	VIS	BEFESTIGUNGSSCHRAUBE	TORNILLO DE SUJECION	
4	III	SUPPORTO ALBERO USCITA	ECE SHAFT OUTPUT SUPPORT				
5	III	CUSCINETTO	BEARING	ROULEMENT	WÄZLAGER	RODAMIENTO	
6	III	SEEGER	CIRCLIP	CIRCLIP	SICHERUNGSRING	SEEGER	
7	III	DADO	NUT	ECROU	MUTTER	TUERCA	
8	III	SCHNORR					
9	III	GUARNIZIONE	GASKET	JOINT PAPIER	DICHTUNG	JUNTA	
10	III	TAPPO	PLUG	BOUCHON	VERSCHLUSS	TAPON	
<b>FS</b>							
11	III	ANELLO DI TENUTA	RUBBER SEAL RING	BASQUE D'ÉTANCHÉITÉ	DICHTUNGSRING		
12	III	SEEGER	CIRCLIP	CIRCLIP	SICHERUNGSRING	SEEGER	
13	III	VITE DI FISSAGGIO	SCREW	VIS	BEFESTIGUNGSSCHRAUBE	TORNILLO DE SUJECION	
14	III	SUPPORTO ALBERO USCITA	ECE SHAFT OUTPUT SUPPORT				
15	III	CUSCINETTO	BEARING	ROULEMENT	WÄZLAGER	RODAMIENTO	
16	III	SEEGER	CIRCLIP	CIRCLIP	SICHERUNGSRING	SEEGER	
17	III	GUARNIZIONE	GASKET	JOINT PAPIER	DICHTUNG	JUNTA	
18	III	TAPPO	PLUG	BOUCHON	VERSCHLUSS	TAPON	
21	III	GUARNIZIONE	GASKET	JOINT PAPIER	DICHTUNG	JUNTA	
22	III	TAPPO	PLUG	BOUCHON	VERSCHLUSS	TAPON	
23	III	PORTASATELLITI/ALBERO USCITA					Vedere Tavola IV
24	III	PORTASATELLITI/ALBERO USCITA					Vedere Tavola IV

## TAVOLA IV

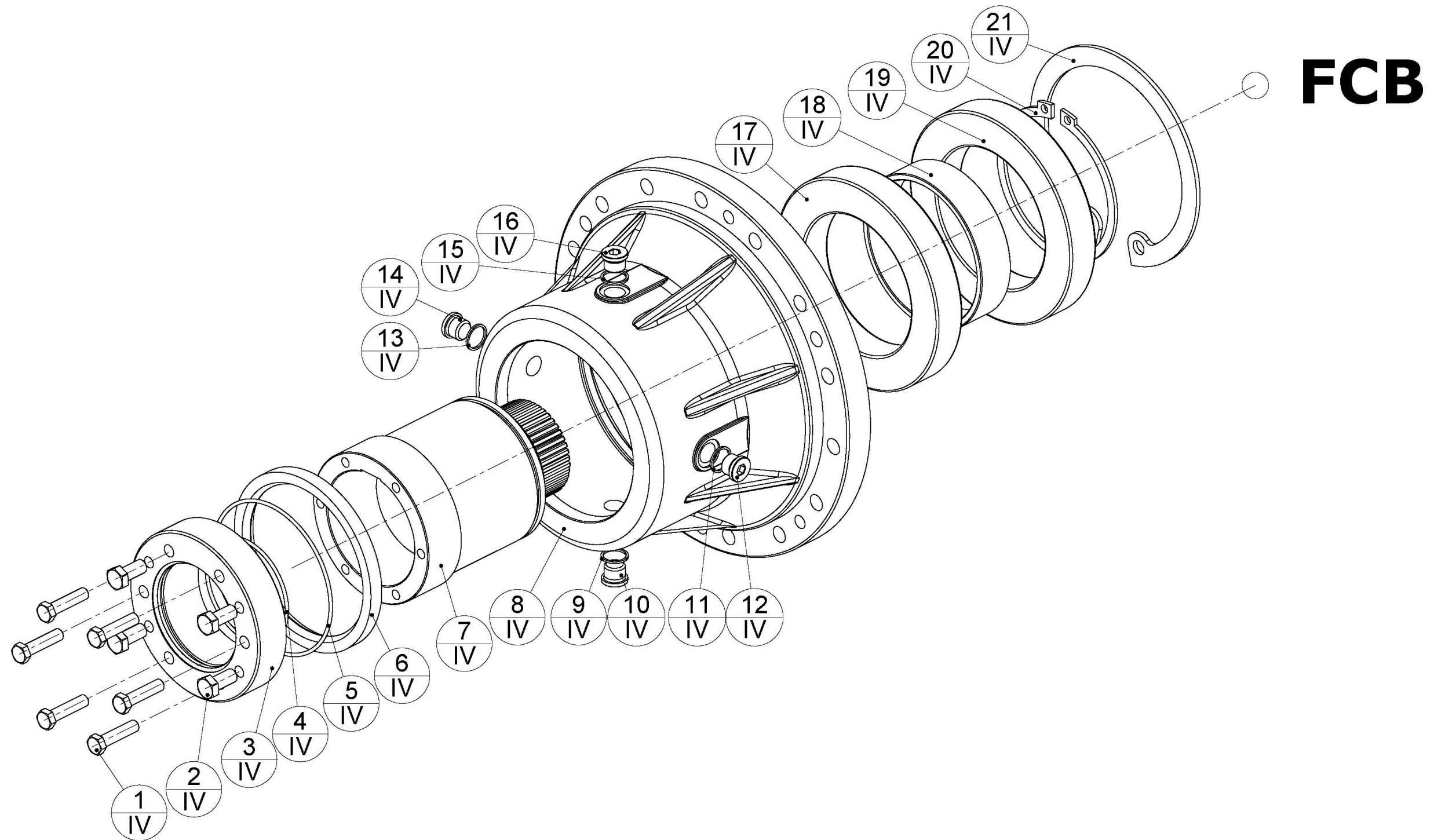

## TAV. IV



**PARTI DI RICAMBIO  
SPARE LISTS**

**NORM0265-R2**

Del 23/02/2012

Pag.13 di 43

STM spa  
VIA DEL MACCABRECCIA , 39  
40012 - CALDERARA DI RENO (BO)  
ITALY  
E-mail: [stm@stmspa.com](mailto:stm@stmspa.com)  
TEL ++ 39 051.646711 FAX ++ 39 051.6466178

EX

-

EX

**TAVOLA IV**

ITEM	TAVOLA	DESCRIZIONE ( I )	DESCRIPTION ( GB )	DESIGNATION ( F )	BEZEICHNUNG ( D )	DENOMINACION ( E )	NOTE
<b>FCB</b>							
1	IV	VITE DI FISSAGGIO	SCREW	VIS	BEFESTIGUNGSSCHRAUBE	TORNILLO DE SUJECION	
2	IV	VITE ESTRAZIONE					
3	IV	COPERCHIO PROTEZIONE					
4	IV	GUARN OR					
5	IV	GUARN OR					
6	IV	ANELLO DI TENUTA	RUBBER SEAL RING	BASQUE D'ÉTANCHÉITÉ	DICHTUNGSRING		
7	IV	ALBERO USCITA	OUTPUT SHAFT	ARBRE SORTIE	ABTRIEBSWELLE	EJE SALIDA	
8	IV	SUPPORTO ALBERO USCITA	ECE SHAFT OUTPUT SUPPORT				
9	IV	GUARNIZIONE	GASKET	JOINT PAPIER	DICHTUNG	JUNTA	
10	IV	TAPPO	PLUG	BOUCHON	VERSCHLUSS	TAPON	
11	IV	GUARNIZIONE	GASKET	JOINT PAPIER	DICHTUNG	JUNTA	
12	IV	TAPPO	PLUG	BOUCHON	VERSCHLUSS	TAPON	
13	IV	GUARNIZIONE	GASKET	JOINT PAPIER	DICHTUNG	JUNTA	
14	IV	TAPPO	PLUG	BOUCHON	VERSCHLUSS	TAPON	
15	IV	GUARNIZIONE	GASKET	JOINT PAPIER	DICHTUNG	JUNTA	
16	IV	TAPPO	PLUG	BOUCHON	VERSCHLUSS	TAPON	
17	IV	CUSCINETTO	BEARING	ROULEMENT	WÄLZLAGER	RODAMIENTO	
18	IV	DISTANZIALE	SPACER RING	ENTRETOISE	DISTANZSCHEIBE	ESPACIADOR	
19	IV	CUSCINETTO	BEARING	ROULEMENT	WÄLZLAGER	RODAMIENTO	
20	IV	SEEGER	CIRCLIP	CIRCLIP	SICHERUNGSRING	SEEGER	
21	IV	SEEGER	CIRCLIP	CIRCLIP	SICHERUNGSRING	SEEGER	

EX

EX

### TAVOLA V

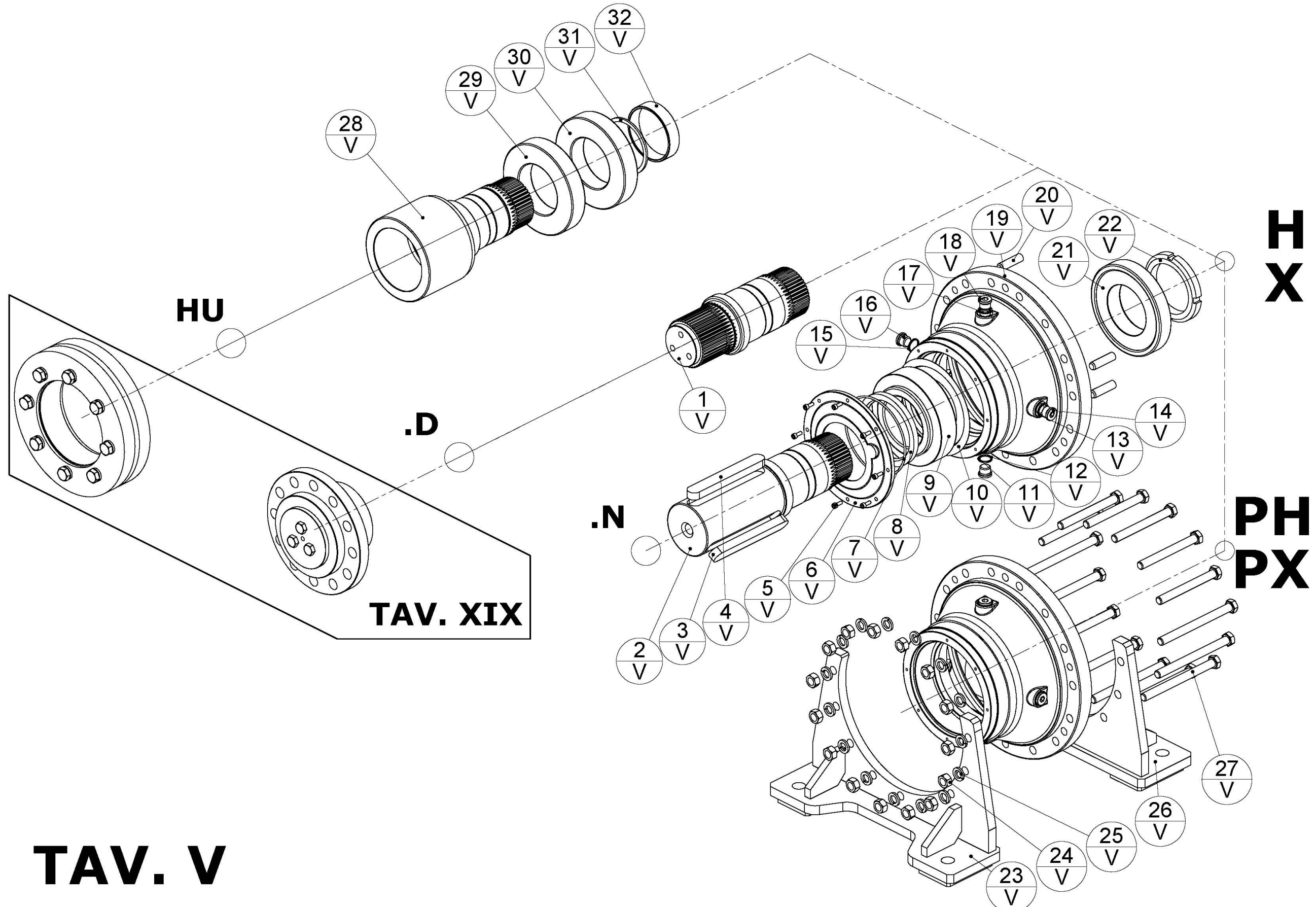

# TAV. V



**PARTI DI RICAMBIO  
SPARE LISTS**

**NORM0265-R2**  
Del 23/02/2012  
Pag.15 di 43

STM spa  
VIA DEL MACCABRECCIA , 39  
40012 - CALDERARA DI RENO (BO)  
ITALY  
E-mail: [stm@stmspa.com](mailto:stm@stmspa.com)  
TEL ++ 39.051.646711 FAX. ++ 39.051.6466178

EX

-

EX

**TAVOLA V**

ITEM	TAVOLA	DESCRIZIONE ( I )	DESCRIPTION ( GB )	DESIGNATION ( F )	BEZEICHNUNG ( D )	DENOMINACION ( E )	NOTE
<b>H - PH X - PX</b>							
1	V	ALBERO USCITA	OUTPUT SHAFT	ARBRE SORTIE	ABTRIEBSWELLE	EJE SALIDA	
2	V	ALBERO USCITA	OUTPUT SHAFT	ARBRE SORTIE	ABTRIEBSWELLE	EJE SALIDA	
3	V	LINGUETTA	KEY	CLAVETTE	PASSFEDER	CHAVETA	
4	V	LINGUETTA	KEY	CLAVETTE	PASSFEDER	CHAVETA	
5	V	VITE DI FISSAGGIO	SCREW	VIS	BEFESTIGUNGSSCHRAUBE	TORNILLO DE SUJECION	
6	V	COPERCHIO USCITA	OUTPUT COVER				
7	V	GUARN OR					
8	V	ANELLO DI TENUTA	RUBBER SEAL RING	BASQUE D'ÉTANCHÉITÉ	DICHTUNGSRING		
9	V	CUSCINETTO	BEARING	ROULEMENT	WÄZLAGER		
10	V	ANELLO NILOS	NILOS RING				
11	V	GUARNIZIONE	GASKET	JOINT PAPIER	DICHTUNG	JUNTA	
12	V	TAPPO	PLUG	BOUCHON	VERSCHLUSS	TAPON	
13	V	GUARNIZIONE	GASKET	JOINT PAPIER	DICHTUNG	JUNTA	
14	V	TAPPO	PLUG	BOUCHON	VERSCHLUSS	TAPON	
15	V	GUARNIZIONE	GASKET	JOINT PAPIER	DICHTUNG	JUNTA	
16	V	TAPPO	PLUG	BOUCHON	VERSCHLUSS	TAPON	
17	V	GUARNIZIONE	GASKET	JOINT PAPIER	DICHTUNG	JUNTA	
18	V	TAPPO	PLUG	BOUCHON	VERSCHLUSS	TAPON	
19	V	SUPPORTO ALBERO USCITA	ECE SHAFT OUTPUT SUPPORT				
20	V	SPINA	PIN	GOUPILLE	STIFT	ESPINA	
21	V	CUSCINETTO	BEARING	ROULEMENT	WÄZLAGER		
22	V	GHIERA DI REGOLAZIONE	ADJUSTMENT GROOVE NUT	FRETTE DE REGLAGE	EINSTELL-NUTMUTTER	TUERCA ACANALADA	
23	V	PIEDE	FOOT	PATTE	FUSS	PIE	
24	V	DADO	NUT	ECROU	MUTTER	TUERCA	
25	V	GROWER	SPRING WASHER	RONDELLE FREIN	FEDERRING	GROWER	
26	V	PIEDE	FOOT	PATTE	FUSS	PIE	
27	V	BULLONE					
28	V	ALBERO USCITA	OUTPUT SHAFT	ARBRE SORTIE	ABTRIEBSWELLE	EJE SALIDA	
29	V	CUSCINETTO	BEARING	ROULEMENT	WÄZLAGER		
30	V	CUSCINETTO	BEARING	ROULEMENT	WÄZLAGER		
31	V	SEEGER	CIRCLIP	CIRCLIP	SICHERUNGSRING	SEEGER	
32	V	DISTANZIALE	SPACER RING	ENTRETOISE	DISTANZSCHEIBE	ESPACIADOR	





**PARTI DI RICAMBIO  
SPARE LISTS**

**NORM0265-R2**  
Del 23/02/2012  
Pag.16 di 43

STM spa  
VIA DEL MACCABRECCIA, 39  
40012 - CALDERARA DI RENO (BO)  
ITALY  
E-mail: [stm@stmspa.com](mailto:stm@stmspa.com)  
TEL ++ 39 051.646711 FAX ++ 39 051.6466178

EX

EX

**TAVOLA VI**

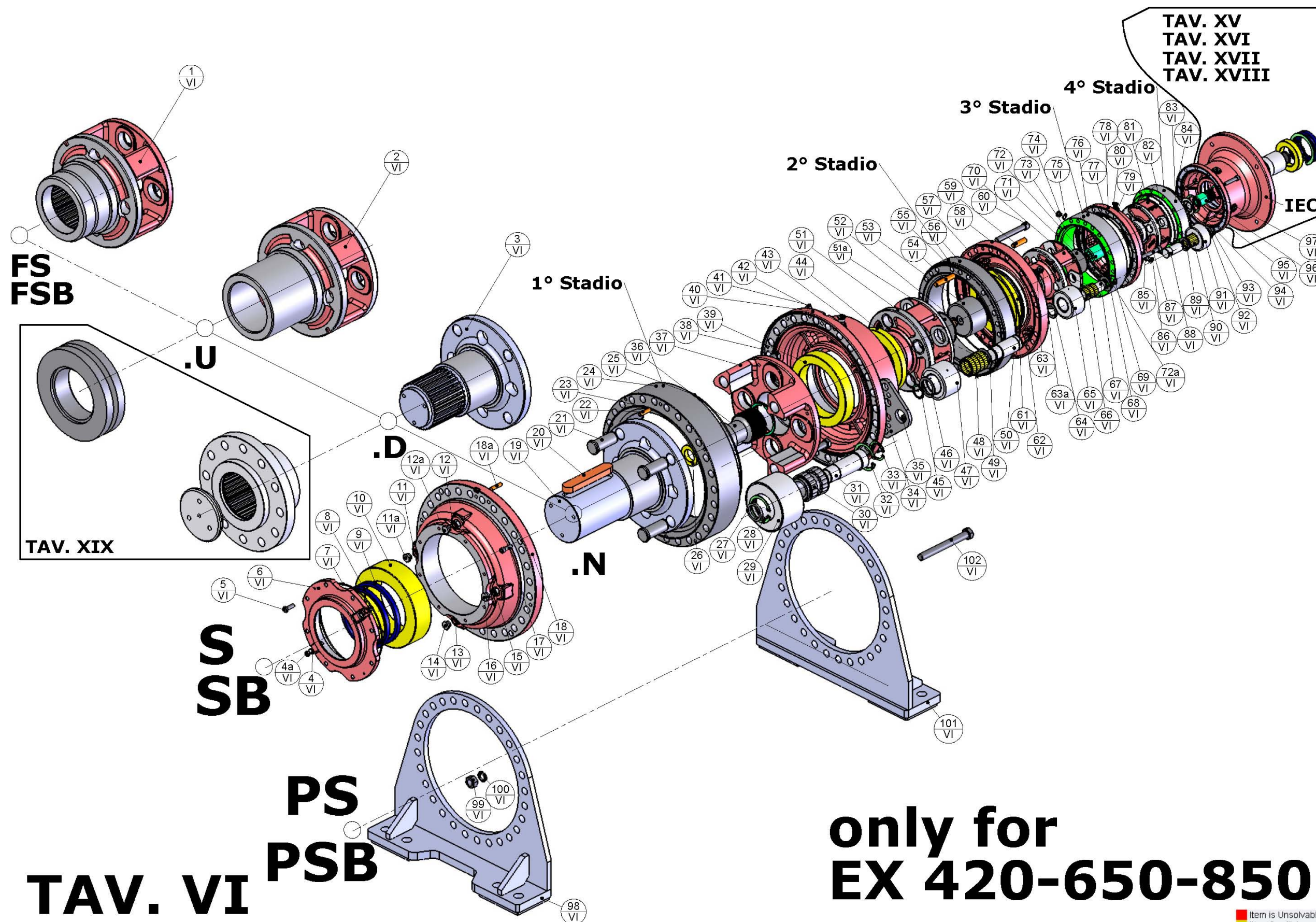

**only for  
EX 420-650-850**

■ Item is Unsolvabile  
■ Item Conflicts



**PARTI DI RICAMBIO  
SPARE LISTS**

**NORM0265-R2**

Del 23/02/2012

Pag.17 di 43

STM spa  
VIA DEL MACCABRECCIA , 39  
40012 - CALDERARA DI RENO (BO)  
ITALY  
E-mail: [stm@stmspa.com](mailto:stm@stmspa.com)  
TEL ++ 39 051.646711 FAX ++ 39 051.6466178

EX

EX

**TAVOLA VI**

ITEM	TAVOLA	DESCRIZIONE ( I )	DESCRIPTION ( GB )	DESIGNATION ( F )	BEZEICHNUNG ( D )	DENOMINACION ( E )	NOTE
<b>S - PS - SB - PSB - FS - FSB - SU</b>							
1	VI	ALBERO USCITA <b>FS-FSB</b>	OUTPUT SHAFT <b>FS-FSB</b>	ARBRE SORTIE <b>FS-FSB</b>	ABTRIEBSWELLE <b>FS-FSB</b>	EJE SALIDA <b>FS-FSB</b>	
2	VI	ALBERO USCITA <b>SU</b>	OUTPUT SHAFT <b>SU</b>	ARBRE SORTIE <b>SU</b>	ABTRIEBSWELLE <b>SU</b>	EJE SALIDA <b>SU</b>	
3	VI	ALBERO USCITA <b>SD</b>	OUTPUT SHAFT <b>SD</b>	ARBRE SORTIE <b>SD</b>	ABTRIEBSWELLE <b>SD</b>	EJE SALIDA <b>SD</b>	
4	VI	GUARNIZIONE	GASKET	JOINT PAPIER	DICHTUNG	JUNTA	
4a	VI	TAPPO	PLUG	BOUCHON	VERSCHLUSS	TAPON	
5	VI	VITE DI FISSAGGIO	SCREW	VIS	BEFESTIGUNGSSCHRAUBE	TORNILLO DE SUJECION	
6	VI	COPERCHIO USCITA	OUTPUT COVER				
7	VI	GUARN OR					
8	VI	ANELLO DI TENUTA	RUBBER SEAL RING	BASQUE D'ÉTANCHÉITÉ	DICHTUNGSRING		
9	VI	ANELLO DI TENUTA	RUBBER SEAL RING	BASQUE D'ÉTANCHÉITÉ	DICHTUNGSRING		
10	VI	CUSCINETTO	BEARING	ROULEMENT	WÄZLAGER	RODAMIENTO	
11	VI	GUARNIZIONE	GASKET	JOINT PAPIER	DICHTUNG	JUNTA	
11a	VI	TAPPO	PLUG	BOUCHON	VERSCHLUSS	TAPON	
12	VI	GUARNIZIONE	GASKET	JOINT PAPIER	DICHTUNG	JUNTA	
12a	VI	TAPPO	PLUG	BOUCHON	VERSCHLUSS	TAPON	
13	VI	GUARNIZIONE	GASKET	JOINT PAPIER	DICHTUNG	JUNTA	
14	VI	TAPPO	PLUG	BOUCHON	VERSCHLUSS	TAPON	
15	VI	GUARNIZIONE	GASKET	JOINT PAPIER	DICHTUNG	JUNTA	
16	VI	TAPPO	PLUG	BOUCHON	VERSCHLUSS	TAPON	
17	VI	VITE DI FISSAGGIO	SCREW	VIS	BEFESTIGUNGSSCHRAUBE	TORNILLO DE SUJECION	
18	VI	SUPPORTO ALBERO USCITA	ECE SHAFT OUTPUT SUPPORT				
18a	VI	SPINA	PIN				
19	VI	ALBERO USCITA <b>SN</b>	OUTPUT SHAFT <b>SN</b>	ARBRE SORTIE <b>SN</b>	ABTRIEBSWELLE <b>SN</b>	EJE SALIDA <b>SN</b>	
20	VI	LINGUETTA	KEY	CLAVETTE	PASSFEDER	CHAVETA	
21	VI	PERNO FISSAGGIO					
22	VI	SPINA	PIN				
23	VI	GUARN OR					
24	VI	CORONA	WORMWHEEL	ROUE	SCHNECKENRAD	ENGRANAJE	
25	VI	GUARN OR					
26	VI	CUSCINETTO	BEARING	ROULEMENT	WÄZLAGER	RODAMIENTO	
27	VI	DISTANZIALE					
28	VI	SEEGER	CIRCLIP	CIRCLIP	SICHERUNGSRING	SEEGER	
29	VI	SATELLITE	PLANET DISK				
30	VI	CUSCINETTO	BEARING	ROULEMENT	WÄZLAGER	RODAMIENTO	
31	VI	PERNO SATELLITE					
32	VI	SEEGER	CIRCLIP	CIRCLIP	SICHERUNGSRING	SEEGER	
33	VI	SEEGER	CIRCLIP	CIRCLIP	SICHERUNGSRING	SEEGER	
34	VI	STAFFA SOLLEVAMENTO					
35	VI	VITE DI FISSAGGIO	SCREW	VIS	BEFESTIGUNGSSCHRAUBE	TORNILLO DE SUJECION	
36	VI	SOLARE	SUN				
37	VI	PORTASATELLITI					
38	VI	VITE DI FISSAGGIO	SCREW	VIS	BEFESTIGUNGSSCHRAUBE	TORNILLO DE SUJECION	
38a	VI	RONDELLA					
39	VI	CUSCINETTO	BEARING	ROULEMENT	WÄZLAGER	RODAMIENTO	
40	VI	FLANGIA	FLANGE	BRIDE	FLANSCH	BRIDA	
41	VI	VITE DI FISSAGGIO	SCREW	VIS	BEFESTIGUNGSSCHRAUBE	TORNILLO DE SUJECION	
42	VI	GUARNIZIONE	GASKET	JOINT PAPIER	DICHTUNG	JUNTA	
43	VI	TAPPO	PLUG	BOUCHON	VERSCHLUSS	TAPON	



**PARTI DI RICAMBIO  
SPARE LISTS**

**NORM0265-R2**  
Del 23/02/2012  
Pag.18 di 43

STM spa  
VIA DEL MACCABRECCIA , 39  
40012 - CALDERARA DI RENO (BO)  
ITALY  
E-mail: [stm@stmspa.com](mailto:stm@stmspa.com)  
TEL ++ 39.051.646711 FAX ++ 39.051.6466178

EX

-

EX

**TAVOLA VI**

ITEM	TAVOLA	DESCRIZIONE ( I )	DESCRIPTION ( GB )	DESIGNATION ( F )	BEZEICHNUNG ( D )	DENOMINACION ( E )	NOTE
44	VI	CUSCINETTO	BEARING	ROULEMENT	WÄZLAGER	RODAMIENTO	
45	VI	SEEGER	CIRCLIP	CIRCLIP	SICHERUNGSRING	SEEGER	
46	VI	RASAMENTO	SHIM	CALE	EINSTELLSCHEIBE	ESPEJOR	
47	VI	SATELLITE	PLANET DISK				
48	VI	CUSCINETTO A RULLINI	NEEDLE BEARING	ROULEMENT A GALETS	NADELLAGER	RODAMIENTO A RODILLOS	
49	VI	RASAMENTO	SHIM	CALE	EINSTELLSCHEIBE	ESPEJOR	
50	VI	PERNO SATELLITE					
51	VI	PORTASATELLITI					
51a	VI	COPERCHIO	COVER	COUVERCLE	DECKEL	TAPA	
52	VI	RONDELLA					
53	VI	SOLARE	SUN				
54	VI	SPINA	PIN				
55	VI	GUARN OR					
56	VI	CORONA	WORMWHEEL	ROUE	SCHNECKENRAD	ENGRANAJE	
57	VI	GUARN OR					
58	VI	FLANGIA	FLANGE	BRIDE	FLANSCH	BRIDA	
59	VI	SPINA	PIN				
60	VI	VITE DI FISSAGGIO	SCREW	VIS	BEFESTIGUNGSSCHRAUBE	TORNILLO DE SUJECION	
61	VI	CUSCINETTO	BEARING	ROULEMENT	WÄZLAGER	RODAMIENTO	
62	VI	ANELLO ARRESTO					
63	VI	GUARNIZIONE	GASKET	JOINT PAPIER	DICHTUNG	JUNTA	
63a	VI	TAPPO	PLUG	BOUCHON	VERSCHLUSS	TAPON	
64	VI	RASAMENTO	SHIM	CALE	EINSTELLSCHEIBE	ESPEJOR	
65	VI	SATELLITE	PLANET DISK				
66	VI	CUSCINETTO A RULLINI	NEEDLE BEARING	ROULEMENT A GALETS	NADELLAGER	RODAMIENTO A RODILLOS	
67	VI	PERNO SATELLITE					
68	VI	RASAMENTO	SHIM	CALE	EINSTELLSCHEIBE	ESPEJOR	
69	VI	SEEGER	CIRCLIP	CIRCLIP	SICHERUNGSRING	SEEGER	
70	VI	PORTASATELLITI					
71	VI	COPERCHIO	COVER	COUVERCLE	DECKEL	TAPA	
72	VI	RONDELLA					
72a	VI	SOLARE	SUN				
73	VI	GUARN OR					
74	VI	TAPPO	PLUG	BOUCHON	VERSCHLUSS	TAPON	
75	VI	GUARNIZIONE	GASKET	JOINT PAPIER	DICHTUNG	JUNTA	
76	VI	CORONA	WORMWHEEL	ROUE	SCHNECKENRAD	ENGRANAJE	
77	VI	GUARN OR					
78	VI	FLANGIA	FLANGE	BRIDE	FLANSCH	BRIDA	
79	VI	GUARNIZIONE	GASKET	JOINT PAPIER	DICHTUNG	JUNTA	
80	VI	TAPPO	PLUG	BOUCHON	VERSCHLUSS	TAPON	
81	VI	PORTASATELLITI					
82	VI	GUARN OR					
83	VI	CORONA	WORMWHEEL	ROUE	SCHNECKENRAD	ENGRANAJE	
84	VI	GUARN OR					
85	VI	GUARNIZIONE	GASKET	JOINT PAPIER	DICHTUNG	JUNTA	
86	VI	TAPPO	PLUG	BOUCHON	VERSCHLUSS	TAPON	
87	VI	VITE DI FISSAGGIO	SCREW	VIS	BEFESTIGUNGSSCHRAUBE	TORNILLO DE SUJECION	
88	VI	PERNO SATELLITE					
89	VI	RASAMENTO	SHIM	CALE	EINSTELLSCHEIBE	ESPEJOR	
90	VI	CUSCINETTO A RULLINI	NEEDLE BEARING	ROULEMENT A GALETS	NADELLAGER	RODAMIENTO A RODILLOS	
91	VI	SATELLITE	PLANET DISK				



**PARTI DI RICAMBIO  
SPARE LISTS**

**NORM0265-R2**  
Del 23/02/2012  
Pag.19 di 43

STM spa  
VIA DEL MACCABRECCIA , 39  
40012 - CALDERARA DI RENO (BO)  
ITALY  
E-mail: [stm@stmspa.com](mailto:stm@stmspa.com)  
TEL ++ 39.051.6467711 FAX ++ 39.051.6466178

EX

-

EX

**TAVOLA VI**

<b>ITEM</b>	<b>TAVOLA</b>	<b>DESCRIZIONE ( I )</b>	<b>DESCRIPTION ( GB )</b>	<b>DESIGNATION ( F )</b>	<b>BEZEICHNUNG ( D )</b>	<b>DENOMINACION ( E )</b>	<b>NOTE</b>
92	VI	RASAMENTO	SHIM	CALE	EINSTELLSCHEIBE	ESPESOR	
93	VI	SEEGER	CIRCLIP	CIRCLIP	SICHERUNGSRING	SEEGER	
94	VI	COPERCHIO	COVER	COUVERCLE	DECKEL	TAPA	
95	VI	SEEGER	CIRCLIP	CIRCLIP	SICHERUNGSRING	SEEGER	
96	VI	SOLARE	SUN				
97	VI	SEEGER	CIRCLIP	CIRCLIP	SICHERUNGSRING	SEEGER	
98	VI	PIEDE	FOOT	PATTE	FUSS	PIE	
99	VI	DADO	NUT	ECROU	MUTTER	TUERCA	
100	VI	GROWER	SPRING WASHER	RONDELLE FREIN	FEDERRING	GROWER	
101	VI	PIEDE	FOOT	PATTE	FUSS	PIE	
102	VI	BULLONE					

## TAVOLA VII

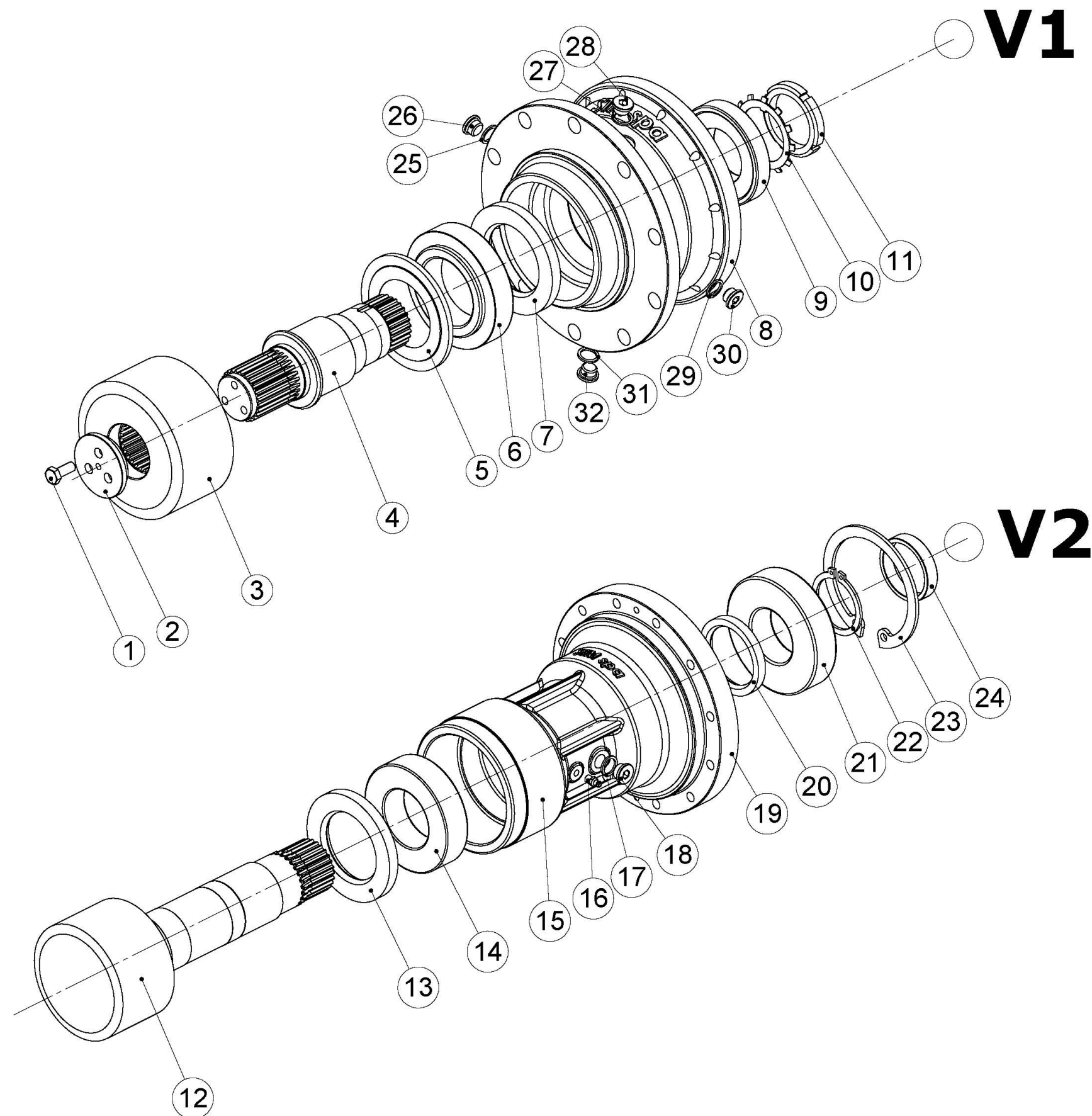

# TAV. VII



**PARTI DI RICAMBIO  
SPARE LISTS**

**NORM0265-R2**  
Del 23/02/2012  
Pag.21 di 43

STM spa  
VIA DEL MACCABRECCIA, 39  
40012 - CALDERARA DI RENO (BO)  
ITALY  
E-mail: [stm@stmspa.com](mailto:stm@stmspa.com)  
TEL ++ 39 051.646711 FAX ++ 39 051.6466178

EX

-

EX

**TAVOLA VII**

ITEM	TAVOLA	DESCRIZIONE ( I )	DESCRIPTION ( GB )	DESIGNATION ( F )	BEZEICHNUNG ( D )	DENOMINACION ( E )	NOTE
<b>VI1</b>							
1	VII	VITE DI FISSAGGIO	SCREW	VIS	BEFESTIGUNGSSCHRAUBE	TORNILLO DE SUJECION	
2	VII	RONDELLA	WASHER	RONDELLE	UNTERLEGSCHIEBE	ARANDELA	
3	VII	PIGNONE CILINDRICO (DentiDiritti)	CYLINDRICAL PINION	PIGNONE CILINDRICO (DentiDiritti)	CYLINDRICAL PINION	PIGNONE CILINDRICO (DentiDiritti)	
4	VII	ALBERO USCITA	OUTPUT SHAFT	ARBRE SORTIE	ABTRIEBSWELLE	EJE SALIDA	
5	VII	NYLOS					
6	VII	CUSCINETTO	BEARING	ROULEMENT	WÄLZLAGER	RODAMIENTO	
7	VII	ANELLO DI TENUTA	RUBBER SEAL RING	BASQUE D'ÉTANCHÉITÉ	DICHTUNGSRING		
8	VII	SUPPORTO ALBERO USCITA	ECE SHAFT OUTPUT SUPPORT				
9	VII	CUSCINETTO	BEARING	ROULEMENT	WÄLZLAGER	RODAMIENTO	
10	VII	ROSETTA SICUREZZA					
11	VII	GHIERA DI REGOLAZIONE	ADJUSTMENT GROOVE NUT	FRETTE DE REGLAGE	EINSTELL-NUTMUTTER	TUERCA ACANALADA	
25	VII	GUARNIZIONE	GASKET	JOINT PAPIER	DICHTUNG	JUNTA	
26	VII	TAPPO	PLUG	BOUCHON	VERSCHLUSS	TAPON	
27	VII	GUARNIZIONE	GASKET	JOINT PAPIER	DICHTUNG	JUNTA	
28	VII	TAPPO	PLUG	BOUCHON	VERSCHLUSS	TAPON	
29	VII	GUARNIZIONE	GASKET	JOINT PAPIER	DICHTUNG	JUNTA	
30	VII	TAPPO	PLUG	BOUCHON	VERSCHLUSS	TAPON	
31	VII	GUARNIZIONE	GASKET	JOINT PAPIER	DICHTUNG	JUNTA	
32	VII	TAPPO	PLUG	BOUCHON	VERSCHLUSS	TAPON	
<b>VI2</b>							
12	VII	PIGNONE CILINDRICO (DentiDiritti)	CYLINDRICAL PINION	PIGNONE CILINDRICO (DentiDiritti)	CYLINDRICAL PINION	PIGNONE CILINDRICO (DentiDiritti)	
13	VII	ANELLO DI TENUTA	RUBBER SEAL RING	BASQUE D'ÉTANCHÉITÉ	DICHTUNGSRING		
14	VII	CUSCINETTO	BEARING	ROULEMENT	WÄLZLAGER	RODAMIENTO	
15	VII	SUPPORTO ALBERO USCITA	ECE SHAFT OUTPUT SUPPORT				
16	VII	INGRASSATORE					
17	VII	GUARNIZIONE	GASKET	JOINT PAPIER	DICHTUNG	JUNTA	
18	VII	TAPPO	PLUG	BOUCHON	VERSCHLUSS	TAPON	
19	VII	SUPPORTO ALBERO USCITA	ECE SHAFT OUTPUT SUPPORT				
20	VII	ANELLO DI TENUTA	RUBBER SEAL RING	BASQUE D'ÉTANCHÉITÉ	DICHTUNGSRING		
21	VII	CUSCINETTO	BEARING	ROULEMENT	WÄLZLAGER	RODAMIENTO	
22	VII	SEEGER	CIRCLIP	CIRCLIP	SICHERUNGSRING	SEEGER	
23	VII	SEEGER	CIRCLIP	CIRCLIP	SICHERUNGSRING	SEEGER	
24	VII	DISTANZIALE	SPACER RING	ENTRETOISE	DISTANZSCHEIBE	ESPACIADOR	



**PARTI DI RICAMBIO  
SPARE LISTS**

**NORM0265-R2**  
Del 23/02/2012  
Pag.22 di 43

STM spa  
VIA DEL MACCABRECCIA, 39  
40012 - CALDERARA DI RENO (BO)  
ITALY  
E-mail: [stm@stmspa.com](mailto:stm@stmspa.com)  
TEL ++ 39.051.646711 FAX ++ 39.051.6466178

EX

EX

**TAVOLA X/1**

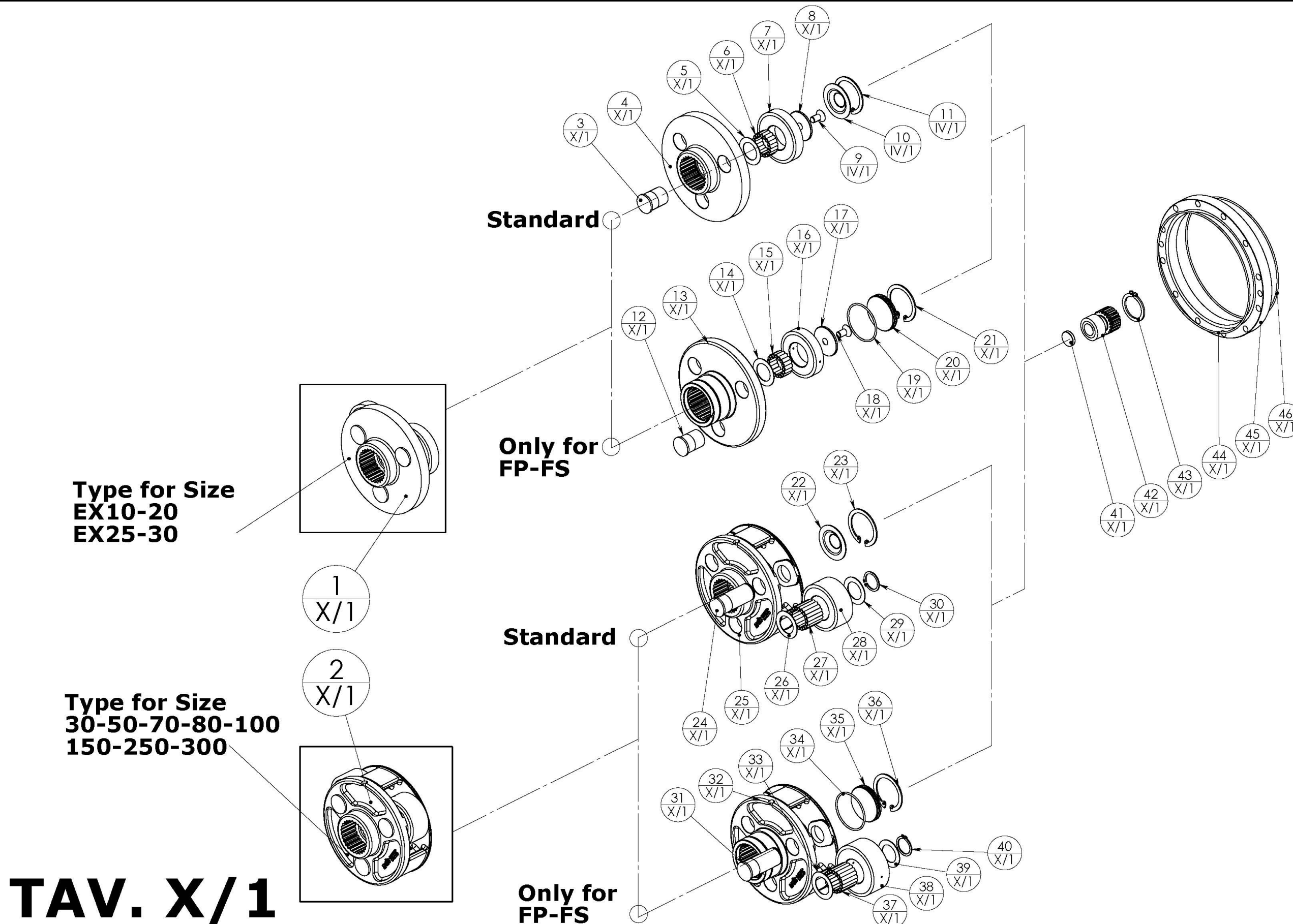



**PARTI DI RICAMBIO  
SPARE LISTS**

**NORM0265-R2**

Del 23/02/2012

Pag.23 di 43

STM spa  
VIA DEL MACCABRECCIA , 39  
40012 - CALDERARA DI RENO (BO)  
ITALY  
E-mail: [stm@stm spa.com](mailto:stm@stm spa.com)  
TEL ++ 39.051.646711 FAX ++ 39.051.6466178

EX

-

EX

**TAVOLA X/1**

ITEM	TAVOLA	DESCRIZIONE (I)	DESCRIPTION (GB)	DESIGNATION (F)	BEZEICHNUNG (D)	DENOMINACION (E)	NOTE
1	X/1	MODULO					
2	X/1	MODULO					
3	X/1	PERNO SATELLITE					
4	X/1	PORTASATELLITI					
5	X/1	RASAMENTO	SHIM	CALE	EINSTELLSCHEIBE	ESPESOR	
6	X/1	CUSCINETTO A RULLINI	NEEDLE BEARING	ROULEMENT A GALETS	NADELLAGER	RODAMIENTO A RODILLOS	
7	X/1	SATELLITE	PLANET DISK				
8	X/1	RONDELLA					
9	X/1	VITE DI FISSAGGIO	SCREW	VIS	BEFESTIGUNGSSCHRAUBE	TORNILLO DE SUJECION	
10	X/1	COPERCHIO	COVER	COUVERCLE	DECKEL	TAPA	
11	X/1	SEEGER	CIRCLIP	CIRCLIP	SICHERUNGSRING	SEEGER	
12	X/1	PERNO SATELLITE					
13	X/1	PORTASATELLITI X F					
14	X/1	RASAMENTO	SHIM	CALE	EINSTELLSCHEIBE	ESPESOR	
15	X/1	CUSCINETTO A RULLINI	NEEDLE BEARING	ROULEMENT A GALETS	NADELLAGER	RODAMIENTO A RODILLOS	
16	X/1	SATELLITE	PLANET DISK				
17	X/1	RONDELLA					
18	X/1	VITE DI FISSAGGIO	SCREW	VIS	BEFESTIGUNGSSCHRAUBE	TORNILLO DE SUJECION	
19	X/1	O-RING					
20	X/1	COPERCHIO	COVER	COUVERCLE	DECKEL	TAPA	
21	X/1	SEEGER	CIRCLIP	CIRCLIP	SICHERUNGSRING	SEEGER	
22	X/1	COPERCHIO	COVER	COUVERCLE	DECKEL	TAPA	
23	X/1	SEEGER	CIRCLIP	CIRCLIP	SICHERUNGSRING	SEEGER	
24	X/1	PERNO SATELLITE					
25	X/1	PORTASATELLITI					
26	X/1	RASAMENTO	SHIM	CALE	EINSTELLSCHEIBE	ESPESOR	
27	X/1	CUSCINETTO A RULLINI	NEEDLE BEARING	ROULEMENT A GALETS	NADELLAGER	RODAMIENTO A RODILLOS	
28	X/1	SATELLITE	PLANET DISK				
29	X/1	RASAMENTO	SHIM	CALE	EINSTELLSCHEIBE	ESPESOR	
30	X/1	SEEGER	CIRCLIP	CIRCLIP	SICHERUNGSRING	SEEGER	
31	X/1	PERNO SATELLITE					
32	X/1	PORTASATELLITI X F					
33	X/1	RASAMENTO	SHIM	CALE	EINSTELLSCHEIBE	ESPESOR	
34	X/1	O-RING					
35	X/1	COPERCHIO	COVER	COUVERCLE	DECKEL	TAPA	
36	X/1	SEEGER	CIRCLIP	CIRCLIP	SICHERUNGSRING	SEEGER	
37	X/1	CUSCINETTO A RULLINI	NEEDLE BEARING	ROULEMENT A GALETS	NADELLAGER	RODAMIENTO A RODILLOS	
38	X/1	SATELLITE	PLANET DISK				
39	X/1	RASAMENTO	SHIM	CALE	EINSTELLSCHEIBE	ESPESOR	
40	X/1	SEEGER	CIRCLIP	CIRCLIP	SICHERUNGSRING	SEEGER	
41	X/1	RONDELLA					
42	X/1	SOLARE	SUN				
43	X/1	SEEGER	CIRCLIP	CIRCLIP	SICHERUNGSRING	SEEGER	
	X/1	O-RING					
44	X/1	O-RING					
45	X/1	CORONA	WORMWHEEL	ROUE	SCHNECKENRAD	ENGRANAJE	
46	X/1	O-RING					





**PARTI DI RICAMBIO  
SPARE LISTS**

**NORM0265-R2**  
Del 23/02/2012  
Pag.24 di 43

STM spa  
VIA DEL MACCABRECCIA, 39  
40012 - CALDERARA DI RENO (BO)  
ITALY  
E-mail: [stm@stmspa.com](mailto:stm@stmspa.com)  
TEL ++ 39.051.646711 FAX ++ 39.051.6466178

EX

EX

**TAVOLA X/2**

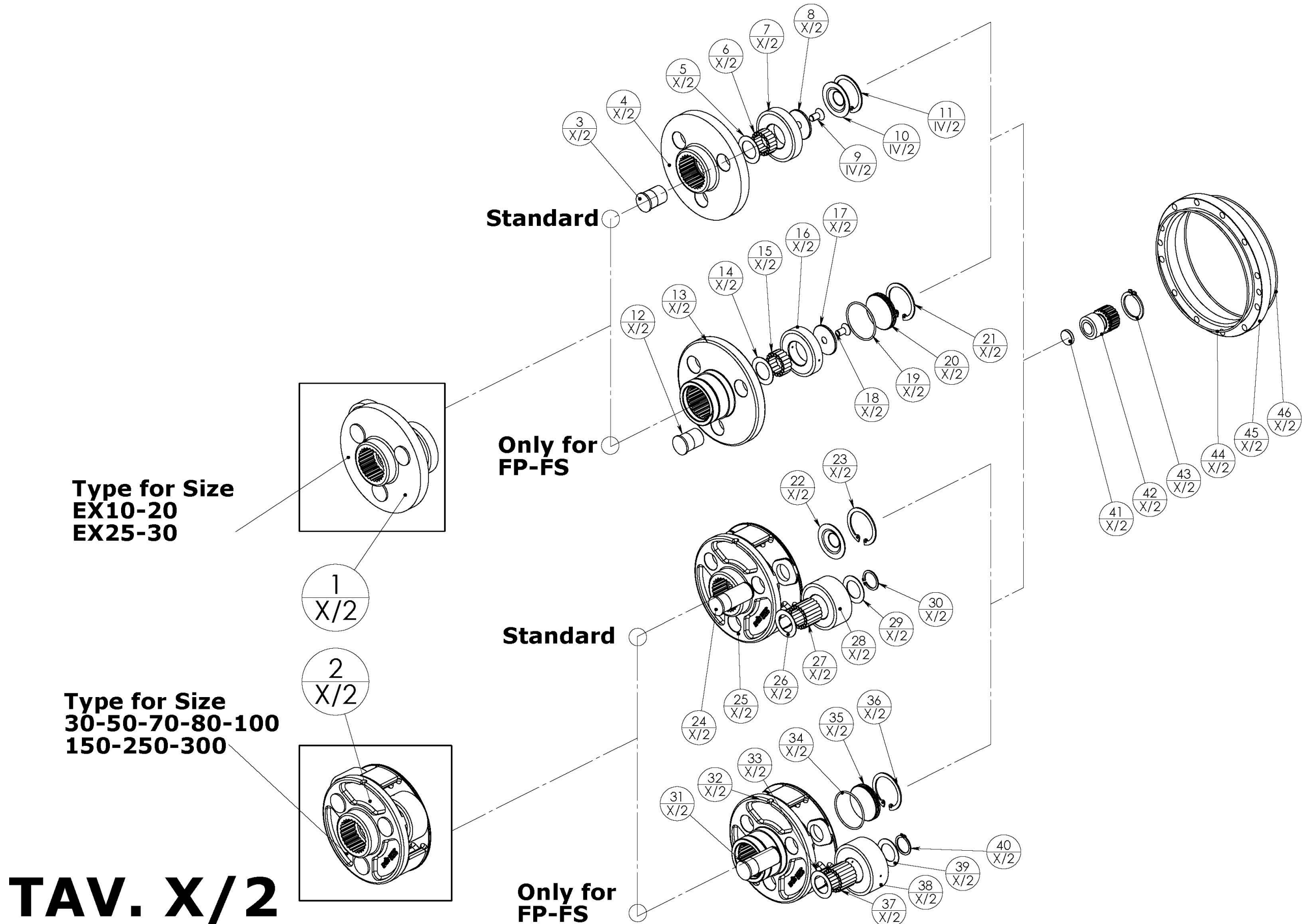

**TAV. X/2**



**PARTI DI RICAMBIO  
SPARE LISTS**

**NORM0265-R2**

Del 23/02/2012

Pag.25 di 43

STM spa  
VIA DEL MACCABRECCIA , 39  
40012 - CALDERARA DI RENO (BO)  
ITALY  
E-mail: [stm@stmspa.com](mailto:stm@stmspa.com)  
TEL ++ 39 051.646711 FAX ++ 39 051.6466178

EX

-

EX

**TAVOLA X/2**

ITEM	TAVOLA	DESCRIZIONE (I)	DESCRIPTION (GB)	DESIGNATION (F)	BEZEICHNUNG (D)	DENOMINACION (E)	NOTE
1	X/2	MODULO					
2	X/2	MODULO					
3	X/2	PERNO SATELLITE					
4	X/2	PORTASATELLITI					
5	X/2	RASAMENTO	SHIM	CALE	EINSTELLSCHEIBE	ESPESOR	
6	X/2	CUSCINETTO A RULLINI	NEEDLE BEARING	ROULEMENT A GALETS	NADELLAGER	RODAMIENTO A RODILLOS	
7	X/2	SATELLITE	PLANET DISK				
8	X/2	RONDELLA					
9	X/2	VITE DI FISSAGGIO	SCREW	VIS	BEFESTIGUNGSSCHRAUBE	TORNILLO DE SUJECION	
10	X/2	COPERCHIO	COVER	COUVERCLE	DECKEL	TAPA	
11	X/2	SEEGER	CIRCLIP	CIRCLIP	SICHERUNGSRING	SEEGER	
12	X/2	PERNO SATELLITE					
13	X/2	PORTASATELLITI X F					
14	X/2	RASAMENTO	SHIM	CALE	EINSTELLSCHEIBE	ESPESOR	
15	X/2	CUSCINETTO A RULLINI	NEEDLE BEARING	ROULEMENT A GALETS	NADELLAGER	RODAMIENTO A RODILLOS	
16	X/2	SATELLITE	PLANET DISK				
17	X/2	RONDELLA					
18	X/2	VITE DI FISSAGGIO	SCREW	VIS	BEFESTIGUNGSSCHRAUBE	TORNILLO DE SUJECION	
19	X/2	O-RING					
20	X/2	COPERCHIO	COVER	COUVERCLE	DECKEL	TAPA	
21	X/2	SEEGER	CIRCLIP	CIRCLIP	SICHERUNGSRING	SEEGER	
22	X/2	COPERCHIO	COVER	COUVERCLE	DECKEL	TAPA	
23	X/2	SEEGER	CIRCLIP	CIRCLIP	SICHERUNGSRING	SEEGER	
24	X/2	PERNO SATELLITE					
25	X/2	PORTASATELLITI					
26	X/2	RASAMENTO	SHIM	CALE	EINSTELLSCHEIBE	ESPESOR	
27	X/2	CUSCINETTO A RULLINI	NEEDLE BEARING	ROULEMENT A GALETS	NADELLAGER	RODAMIENTO A RODILLOS	
28	X/2	SATELLITE	PLANET DISK				
29	X/2	RASAMENTO	SHIM	CALE	EINSTELLSCHEIBE	ESPESOR	
30	X/2	SEEGER	CIRCLIP	CIRCLIP	SICHERUNGSRING	SEEGER	
31	X/2	PERNO SATELLITE					
32	X/2	PORTASATELLITI X F					
33	X/2	RASAMENTO	SHIM	CALE	EINSTELLSCHEIBE	ESPESOR	
34	X/2	O-RING					
35	X/2	COPERCHIO	COVER	COUVERCLE	DECKEL	TAPA	
36	X/2	SEEGER	CIRCLIP	CIRCLIP	SICHERUNGSRING	SEEGER	
37	X/2	CUSCINETTO A RULLINI	NEEDLE BEARING	ROULEMENT A GALETS	NADELLAGER	RODAMIENTO A RODILLOS	
38	X/2	SATELLITE	PLANET DISK				
39	X/2	RASAMENTO	SHIM	CALE	EINSTELLSCHEIBE	ESPESOR	
40	X/2	SEEGER	CIRCLIP	CIRCLIP	SICHERUNGSRING	SEEGER	
41	X/2	RONDELLA					
42	X/2	SOLARE	SUN				
43	X/2	SEEGER	CIRCLIP	CIRCLIP	SICHERUNGSRING	SEEGER	
	X/2	O-RING					
44	X/2	O-RING					
45	X/2	CORONA	WORMWHEEL	ROUE	SCHNECKENRAD	ENGRANAJE	
46	X/2	O-RING					

**TAVOLA X/3**

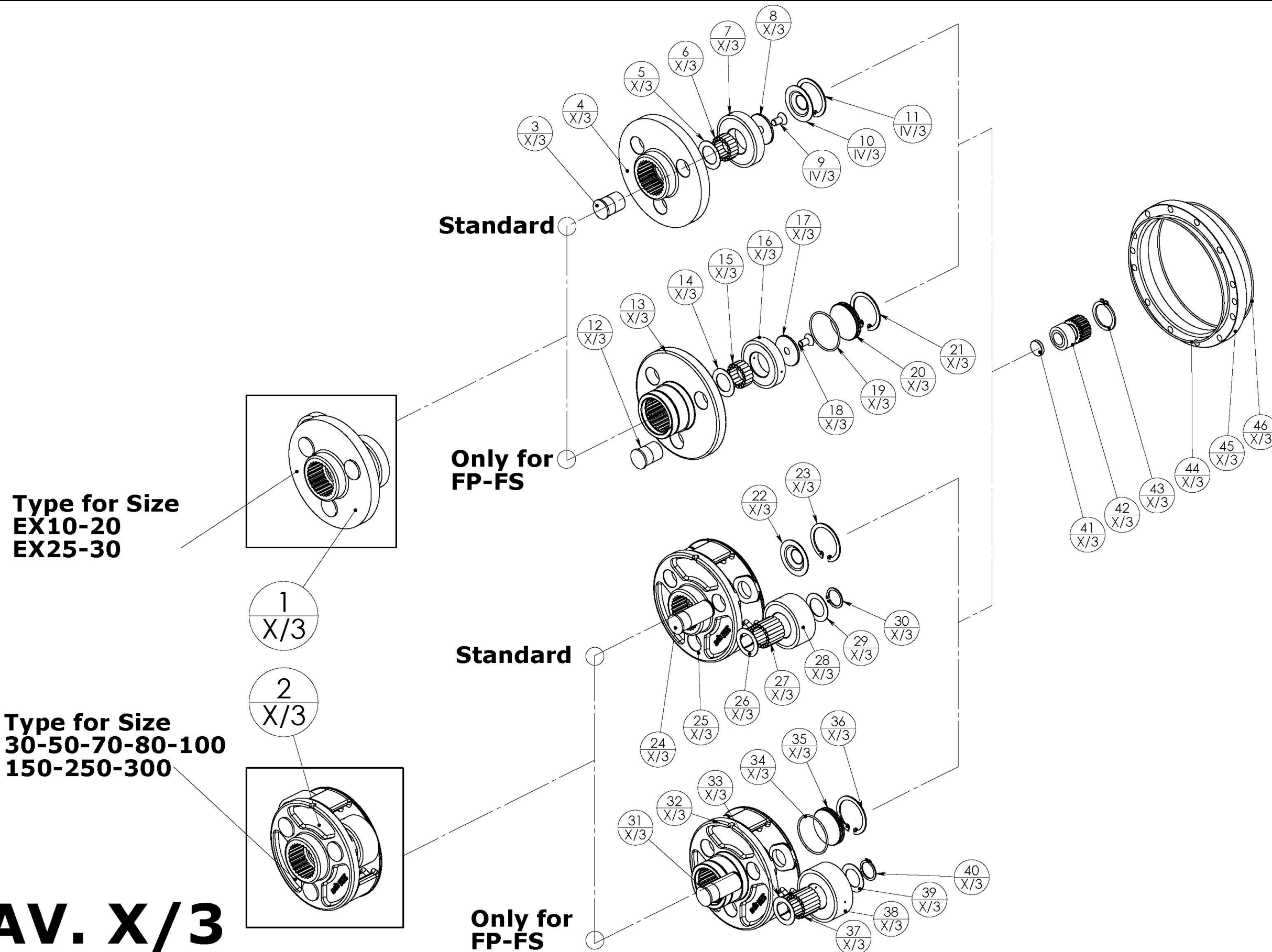

**TAV. X/3**



**PARTI DI RICAMBIO  
SPARE LISTS**

**NORM0265-R2**

Del 23/02/2012

Pag.27 di 43

STM spa  
VIA DEL MACCABRECCIA , 39  
40012 - CALDERARA DI RENO (BO)  
ITALY  
E-mail: [stm@stmspa.com](mailto:stm@stmspa.com)  
TEL ++ 39.051.646711 FAX ++ 39.051.6466178

EX

-

EX

**TAVOLA X/3**

ITEM	TAVOLA	DESCRIZIONE (I)	DESCRIPTION (GB)	DESIGNATION (F)	BEZEICHNUNG (D)	DENOMINACION (E)	NOTE
1	X/3	MODULO					
2	X/3	MODULO					
3	X/3	PERNO SATELLITE					
4	X/3	PORTASATELLITI					
5	X/3	RASAMENTO	SHIM	CALE	EINSTELLSCHEIBE	ESPESOR	
6	X/3	CUSCINETTO A RULLINI	NEEDLE BEARING	ROULEMENT A GALETS	NADELLAGER	RODAMIENTO A RODILLOS	
7	X/3	SATELLITE	PLANET DISK				
8	X/3	RONDELLA					
9	X/3	VITE DI FISSAGGIO	SCREW	VIS	BEFESTIGUNGSSCHRAUBE	TORNILLO DE SUJECION	
10	X/3	COPERCHIO	COVER	COUVERCLE	DECKEL	TAPA	
11	X/3	SEEGER	CIRCLIP	CIRCLIP	SICHERUNGSRING	SEEGER	
12	X/3	PERNO SATELLITE					
13	X/3	PORTASATELLITI X F					
14	X/3	RASAMENTO	SHIM	CALE	EINSTELLSCHEIBE	ESPESOR	
15	X/3	CUSCINETTO A RULLINI	NEEDLE BEARING	ROULEMENT A GALETS	NADELLAGER	RODAMIENTO A RODILLOS	
16	X/3	SATELLITE	PLANET DISK				
17	X/3	RONDELLA					
18	X/3	VITE DI FISSAGGIO	SCREW	VIS	BEFESTIGUNGSSCHRAUBE	TORNILLO DE SUJECION	
19	X/3	O-RING					
20	X/3	COPERCHIO	COVER	COUVERCLE	DECKEL	TAPA	
21	X/3	SEEGER	CIRCLIP	CIRCLIP	SICHERUNGSRING	SEEGER	
22	X/3	COPERCHIO	COVER	COUVERCLE	DECKEL	TAPA	
23	X/3	SEEGER	CIRCLIP	CIRCLIP	SICHERUNGSRING	SEEGER	
24	X/3	PERNO SATELLITE					
25	X/3	PORTASATELLITI					
26	X/3	RASAMENTO	SHIM	CALE	EINSTELLSCHEIBE	ESPESOR	
27	X/3	CUSCINETTO A RULLINI	NEEDLE BEARING	ROULEMENT A GALETS	NADELLAGER	RODAMIENTO A RODILLOS	
28	X/3	SATELLITE	PLANET DISK				
29	X/3	RASAMENTO	SHIM	CALE	EINSTELLSCHEIBE	ESPESOR	
30	X/3	SEEGER	CIRCLIP	CIRCLIP	SICHERUNGSRING	SEEGER	
31	X/3	PERNO SATELLITE					
32	X/3	PORTASATELLITI X F					
33	X/3	RASAMENTO	SHIM	CALE	EINSTELLSCHEIBE	ESPESOR	
34	X/3	O-RING					
35	X/3	COPERCHIO	COVER	COUVERCLE	DECKEL	TAPA	
36	X/3	SEEGER	CIRCLIP	CIRCLIP	SICHERUNGSRING	SEEGER	
37	X/3	CUSCINETTO A RULLINI	NEEDLE BEARING	ROULEMENT A GALETS	NADELLAGER	RODAMIENTO A RODILLOS	
38	X/3	SATELLITE	PLANET DISK				
39	X/3	RASAMENTO	SHIM	CALE	EINSTELLSCHEIBE	ESPESOR	
40	X/3	SEEGER	CIRCLIP	CIRCLIP	SICHERUNGSRING	SEEGER	
41	X/3	RONDELLA					
42	X/3	SOLARE	SUN				
43	X/3	SEEGER	CIRCLIP	CIRCLIP	SICHERUNGSRING	SEEGER	
	X/3	O-RING					
44	X/3	O-RING					
45	X/3	CORONA	WORMWHEEL	ROUE	SCHNECKENRAD	ENGRANAJE	
46	X/3	O-RING					



**PARTI DI RICAMBIO  
SPARE LISTS**

**NORM0265-R2**  
Del 23/02/2012  
Pag.28 di 43

STM spa  
VIA DEL MACCABRECCIA, 39  
40012 - CALDERARA DI RENO (BO)  
ITALY  
E-mail: [stm@stmspa.com](mailto:stm@stmspa.com)  
TEL ++39.051.646711 FAX ++39.051.6466178

EX

EX

**TAVOLA X/4**

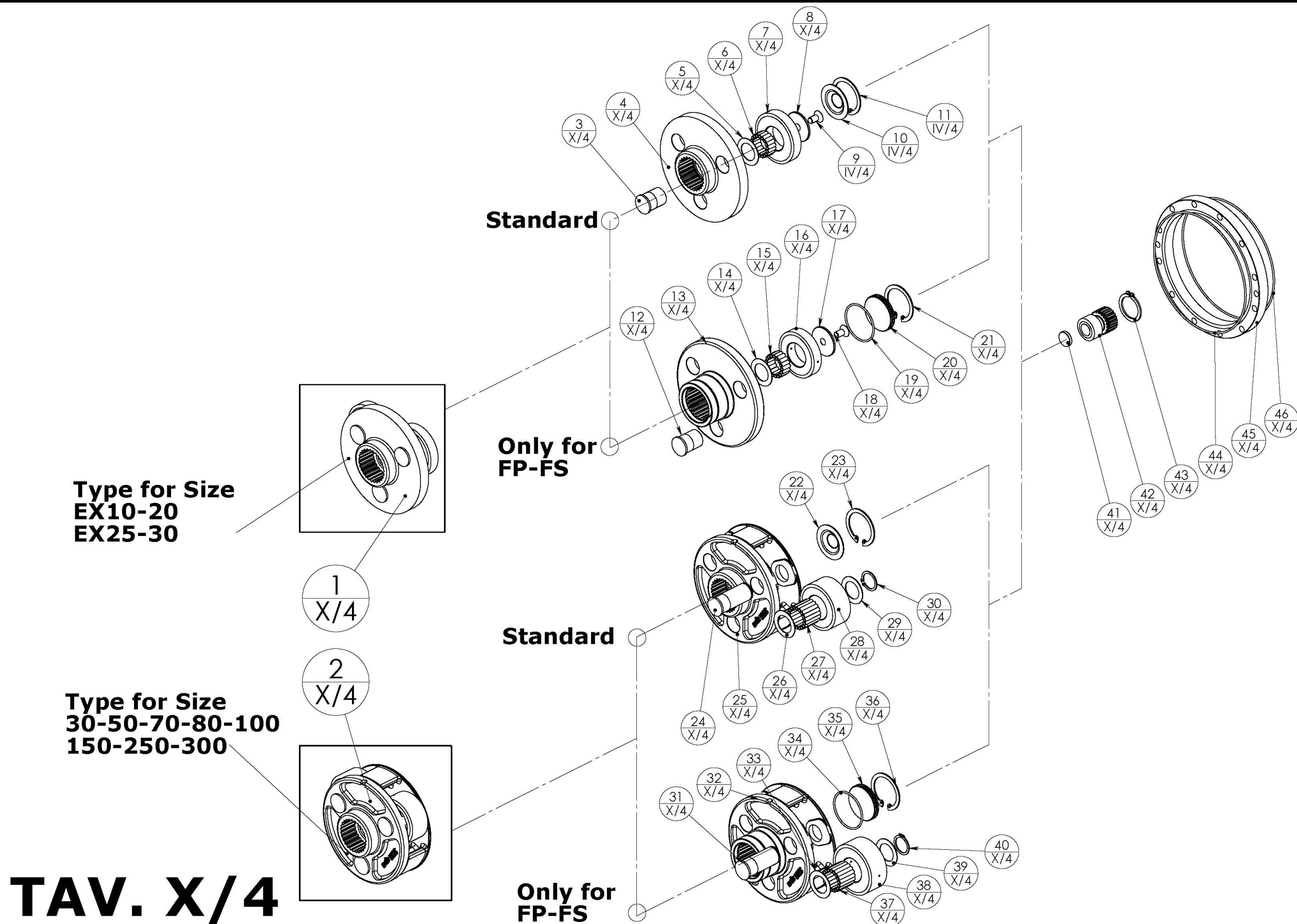

**TAV. X/4**



**PARTI DI RICAMBIO  
SPARE LISTS**

**NORM0265-R2**

Del 23/02/2012

Pag.29 di 43

STM spa  
VIA DEL MACCABRECCIA , 39  
40012 - CALDERARA DI RENO (BO)  
ITALY  
E-mail: [stm@stmspa.com](mailto:stm@stmspa.com)  
TEL ++ 39 051.646711 FAX ++ 39 051.6466178

EX

-

EX

**TAVOLA X/4**

ITEM	TAVOLA	DESCRIZIONE (I)	DESCRIPTION (GB)	DESIGNATION (F)	BEZEICHNUNG (D)	DENOMINACION (E)	NOTE
1	X/4	MODULO					
2	X/4	MODULO					
3	X/4	PERNO SATELLITE					
4	X/4	PORTASATELLITI					
5	X/4	RASAMENTO	SHIM	CALE	EINSTELLSCHIEBE	ESPESOR	
6	X/4	CUSCINETTO A RULLINI	NEEDLE BEARING	ROULEMENT A GALETS	NADELLAGER	RODAMIENTO A RODILLOS	
7	X/4	SATELLITE	PLANET DISK				
8	X/4	RONDELLA					
9	X/4	VITE DI FISSAGGIO	SCREW	VIS	BEFESTIGUNGSSCHRAUBE	TORNILLO DE SUJECION	
10	X/4	COPERCHIO	COVER	COUVERCLE	DECKEL	TAPA	
11	X/4	SEEGER	CIRCLIP	CIRCLIP	SICHERUNGSRING	SEEGER	
12	X/4	PERNO SATELLITE					
13	X/4	PORTASATELLITI X F					
14	X/4	RASAMENTO	SHIM	CALE	EINSTELLSCHIEBE	ESPESOR	
15	X/4	CUSCINETTO A RULLINI	NEEDLE BEARING	ROULEMENT A GALETS	NADELLAGER	RODAMIENTO A RODILLOS	
16	X/4	SATELLITE	PLANET DISK				
17	X/4	RONDELLA					
18	X/4	VITE DI FISSAGGIO	SCREW	VIS	BEFESTIGUNGSSCHRAUBE	TORNILLO DE SUJECION	
19	X/4	O-RING					
20	X/4	COPERCHIO	COVER	COUVERCLE	DECKEL	TAPA	
21	X/4	SEEGER	CIRCLIP	CIRCLIP	SICHERUNGSRING	SEEGER	
22	X/4	COPERCHIO	COVER	COUVERCLE	DECKEL	TAPA	
23	X/4	SEEGER	CIRCLIP	CIRCLIP	SICHERUNGSRING	SEEGER	
24	X/4	PERNO SATELLITE					
25	X/4	PORTASATELLITI					
26	X/4	RASAMENTO	SHIM	CALE	EINSTELLSCHIEBE	ESPESOR	
27	X/4	CUSCINETTO A RULLINI	NEEDLE BEARING	ROULEMENT A GALETS	NADELLAGER	RODAMIENTO A RODILLOS	
28	X/4	SATELLITE	PLANET DISK				
29	X/4	RASAMENTO	SHIM	CALE	EINSTELLSCHIEBE	ESPESOR	
30	X/4	SEEGER	CIRCLIP	CIRCLIP	SICHERUNGSRING	SEEGER	
31	X/4	PERNO SATELLITE					
32	X/4	PORTASATELLITI X F					
33	X/4	RASAMENTO	SHIM	CALE	EINSTELLSCHIEBE	ESPESOR	
34	X/4	O-RING					
35	X/4	COPERCHIO	COVER	COUVERCLE	DECKEL	TAPA	
36	X/4	SEEGER	CIRCLIP	CIRCLIP	SICHERUNGSRING	SEEGER	
37	X/4	CUSCINETTO A RULLINI	NEEDLE BEARING	ROULEMENT A GALETS	NADELLAGER	RODAMIENTO A RODILLOS	
38	X/4	SATELLITE	PLANET DISK				
39	X/4	RASAMENTO	SHIM	CALE	EINSTELLSCHIEBE	ESPESOR	
40	X/4	SEEGER	CIRCLIP	CIRCLIP	SICHERUNGSRING	SEEGER	
41	X/4	RONDELLA					
42	X/4	SOLARE	SUN				
43	X/4	SEEGER	CIRCLIP	CIRCLIP	SICHERUNGSRING	SEEGER	
	X/4	O-RING					
44	X/4	O-RING					
45	X/4	CORONA	WORMWHEEL	ROUE	SCHNECKENRAD	ENGRANAJE	
46	X/4	O-RING					

**TAVOLA XI/2**

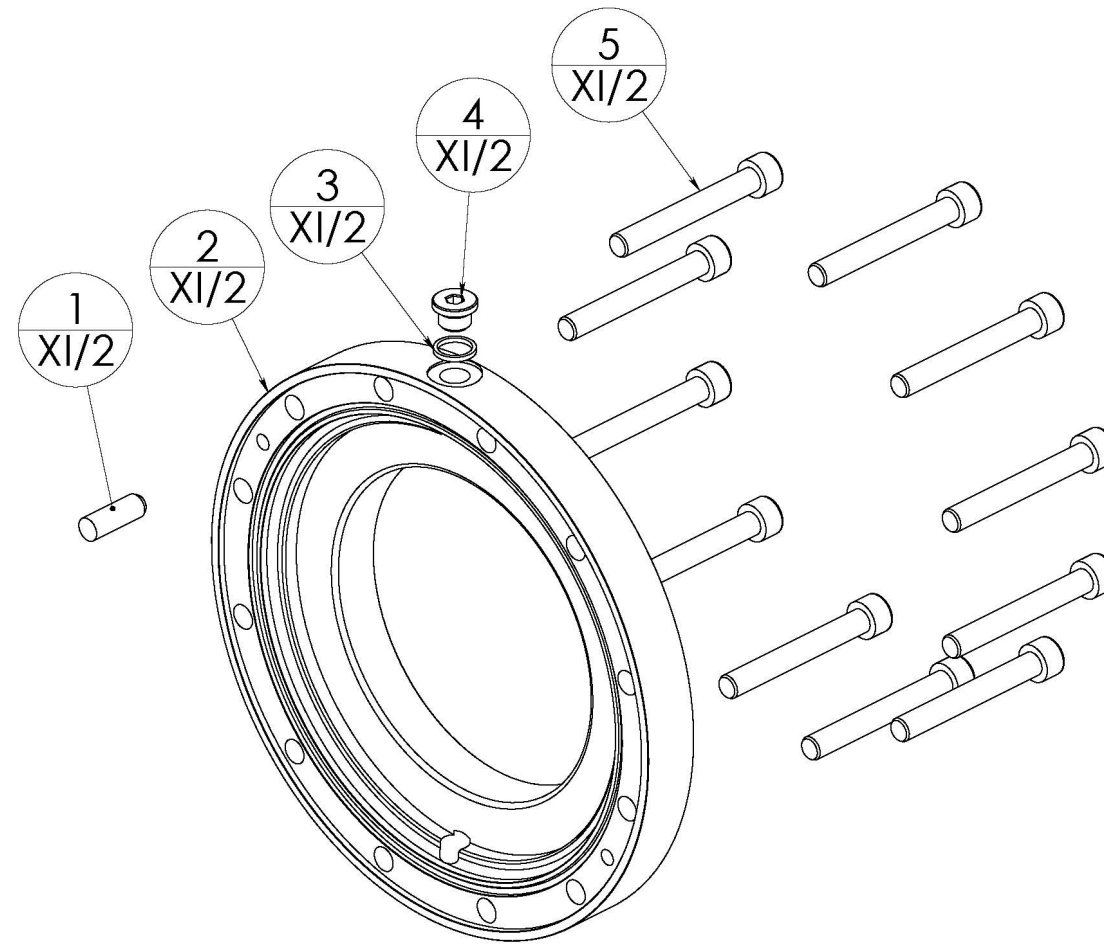

**TAV. XI/2**

**TAVOLA XI/2**

ITEM	TAVOLA	DESCRIZIONE (I)	DESCRIPTION (GB)	DESIGNATION (F)	BEZEICHNUNG (D)	DENOMINACION (E)	NOTE
1	XI/2	SPINA	PIN				
2	XI/2	FLANGIA	FLANGE	BRIDE	FLANSCH	BRIDA	
3	XI/2	GUARNIZIONE	GASKET	JOINT PAPIER	DICHTUNG	JUNTA	
4	XI/2	TAPPO	PLUG	BOUCHON	VERSCHLUSS	TAPON	
5	XI/2	VITE DI FISSAGGIO	SCREW	VIS	BEFESTIGUNGSSCHRAUBE	TORNILLO DE SUJECION	

**TAVOLA XI/3**

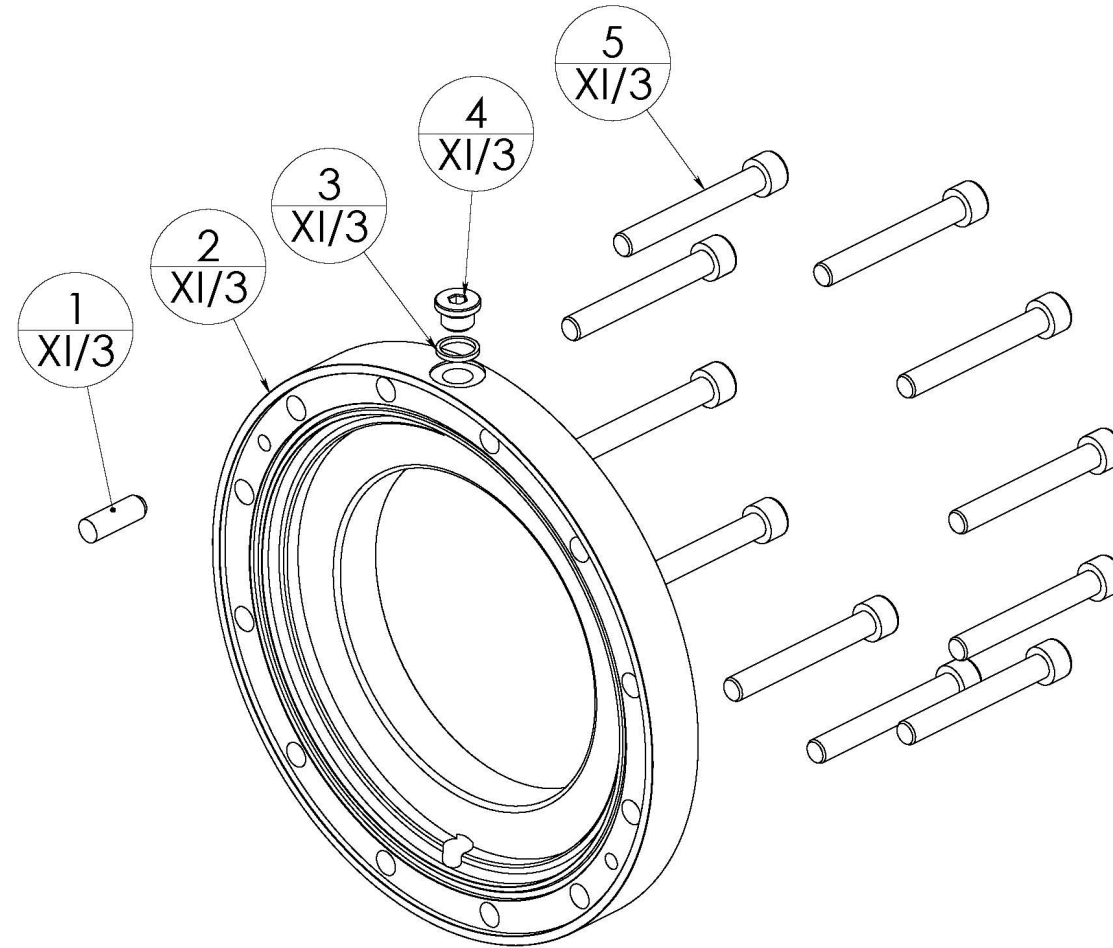

**TAV. XI/3**

**TAVOLA XI/3**

ITEM	TAVOLA	DESCRIZIONE (I)	DESCRIPTION (GB)	DESIGNATION (F)	BEZEICHNUNG (D)	DENOMINACION (E)	NOTE
1	XI/3	SPINA	PIN				
2	XI/3	FLANGIA	FLANGE	BRIDE	FLANSCH	BRIDA	
3	XI/3	GUARNIZIONE	GASKET	JOINT PAPIER	DICHTUNG	JUNTA	
4	XI/3	TAPPO	PLUG	BOUCHON	VERSCHLUSS	TAPON	
5	XI/3	VITE DI FISSAGGIO	SCREW	VIS	BEFESTIGUNGSSCHRAUBE	TORNILLO DE SUJECION	



**TAVOLA XI/4**

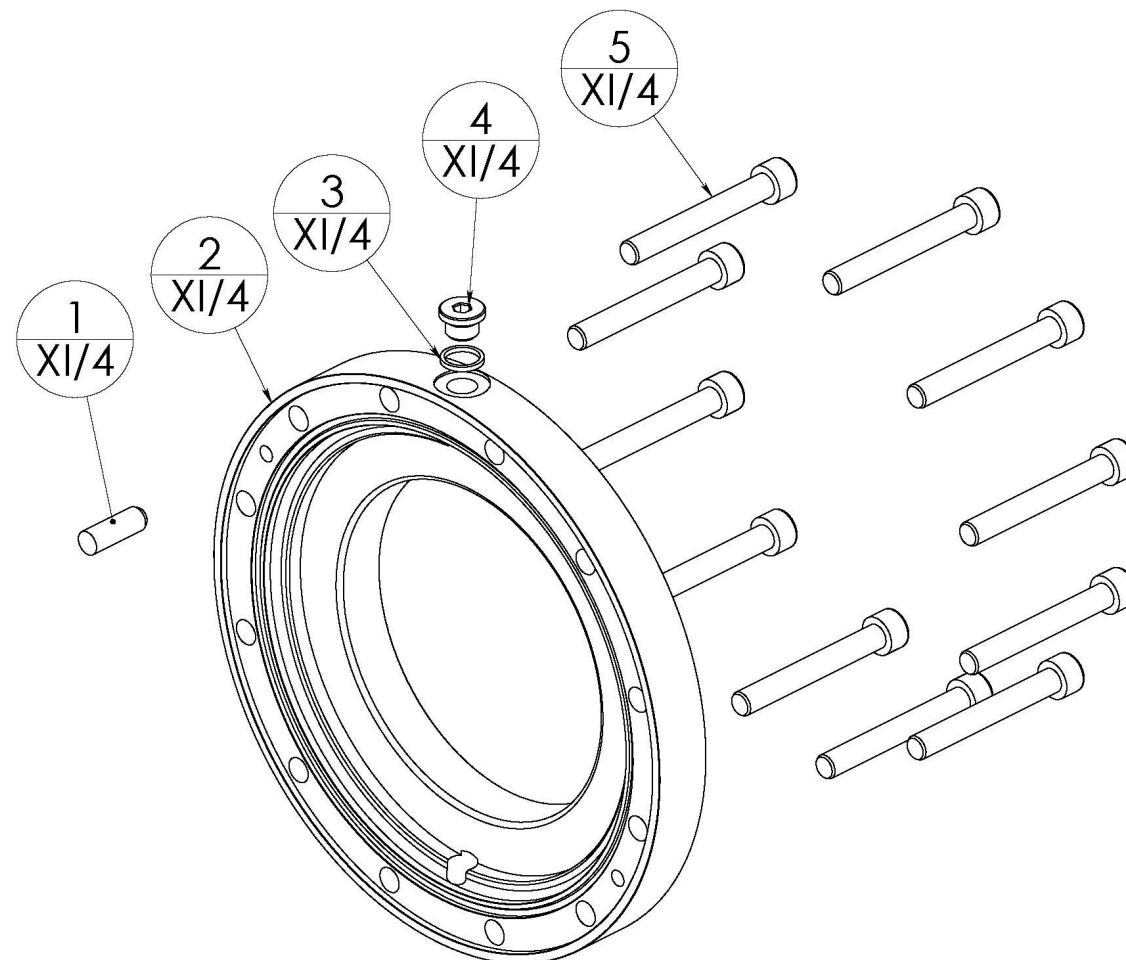

**TAV. XI/4**

**TAVOLA XI/4**

ITEM	TAVOLA	DESCRIZIONE (I)	DESCRIPTION (GB)	DESIGNATION (F)	BEZEICHNUNG (D)	DENOMINACION (E)	NOTE
1	XI/4	SPINA	PIN				
2	XI/4	FLANGIA	FLANGE	BRIDE	FLANSCH	BRIDA	
3	XI/4	GUARNIZIONE	GASKET	JOINT PAPIER	DICHTUNG	JUNTA	
4	XI/4	TAPPO	PLUG	BOUCHON	VERSCHLUSS	TAPON	
5	XI/4	VITE DI FISSAGGIO	SCREW	VIS	BEFESTIGUNGSSCHRAUBE	TORNILLO DE SUJECION	

## TAVOLA XII

### IEC-Diretto

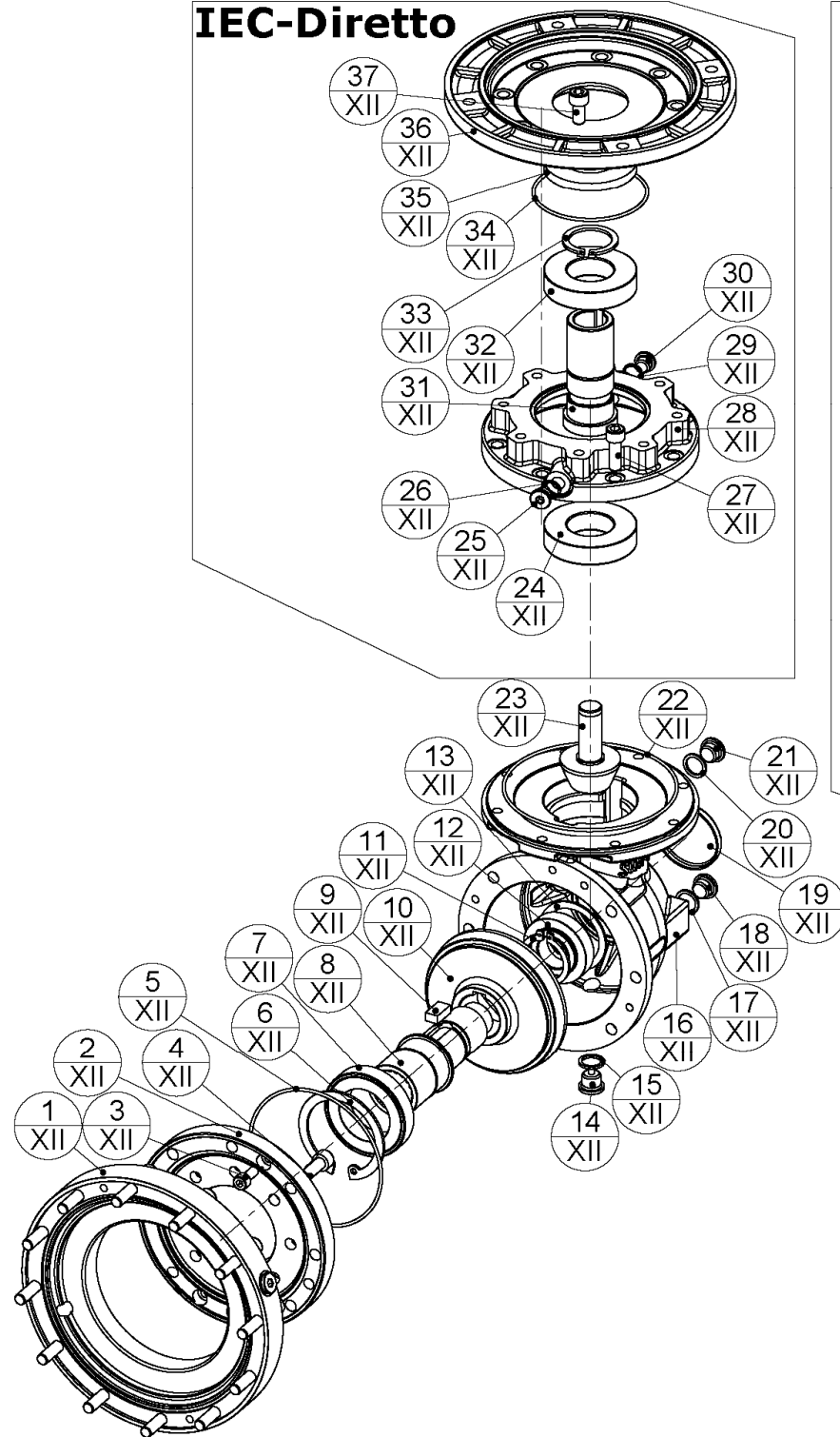

### EU-ECE-ECR-IEC-I-Z

#### TAV. XVI

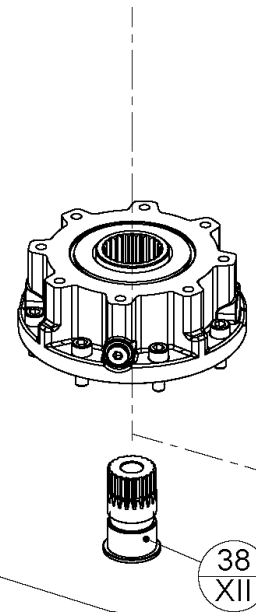

#### TAV. XVII

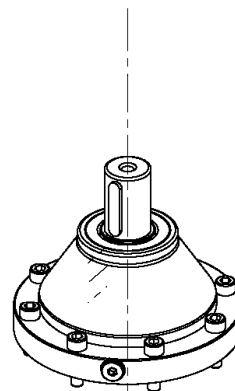

#### TAV. XVIII

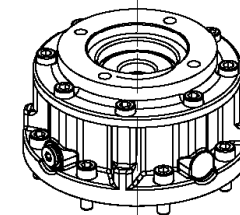

#### TAV. XVIII

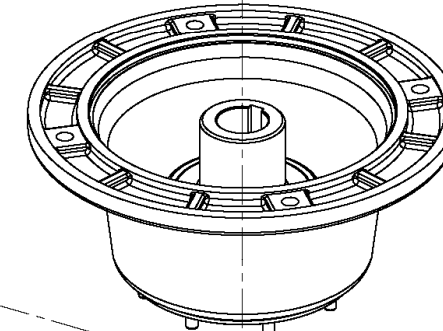

#### TAV. XIII

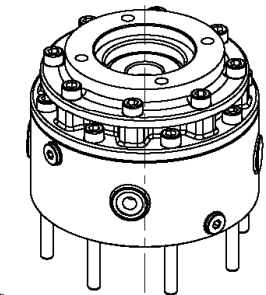

## EXB

## TAV. XII



**PARTI DI RICAMBIO  
SPARE LISTS**

**NORM0265-R2**

Del 23/02/2012

Pag.34 di 43

STM spa  
VIA DEL MACCABRECCIA, 39  
40012 - CALDERARA DI RENO (BO)  
ITALY  
E-mail: [stm@stmspa.com](mailto:stm@stmspa.com)  
TEL ++39 051.646711 FAX ++39 051.6466178

EX

-

EX

**TAVOLA XII**

ITEM	TAVOLA	DESCRIZIONE (I)	DESCRIPTION (GB)	DESIGNATION (F)	BEZEICHNUNG (D)	DENOMINACION (E)	NOTE
1	XII	FLANGIA COMB	FLANGE COMB	BRIDE COMB	FLANSCH COMB	BRIDA COMB	
2	XII	FLANGIA EXB	FLANGE EXB	BRIDE EXB	FLANSCH EXB	BRIDA EXB	
3	XII	VITE DI FISSAGGIO	SCREW	VIS	BEFESTIGUNGSSCHRAUBE	TORNILLO DE SUJECION	
4	XII	VITE DI FISSAGGIO	SCREW	VIS	BEFESTIGUNGSSCHRAUBE	TORNILLO DE SUJECION	
5	XII	GUARN OR					
6	XII	SEEGER	CIRCLIP	CIRCLIP	SICHERUNGSRING	SEEGER	
7	XII	CUSCINETTO	BEARING	ROULEMENT	WÄLZLAGER	RODAMIENTO	
8	XII	ALBERO CORONA					
9	XII	LINGUETTA	KEY	CLAVETTE	PASSFEDER	CHAVETA	
10	XII	CORONA CONICA	BEVEL WHEEL	ROUE CONIC	SCHNECKENRAD	ENGRANAJE	
11	XII	SEEGER	CIRCLIP	CIRCLIP	SICHERUNGSRING	SEEGER	
12	XII	CUSCINETTO	BEARING	ROULEMENT	WÄLZLAGER	RODAMIENTO	
13	XII	SEEGER	CIRCLIP	CIRCLIP	SICHERUNGSRING	SEEGER	
14	XII	TAPPO	PLUG	BOUCHON	VERSCHLUSS	TAPON	
15	XII	GUARNIZIONE	GASKET	JOINT PAPIER	DICHTUNG	JUNTA	
16	XII	SUPPORTO FLAM EXB	IEC FLANGE INPUT SUPPORT EXB	SUPPORT BRIDE MOTEUR EXB	AUFNAHME ANTRIEB IEC FLANSCH EXB	SOPORTE FLAM EXB	
17	XII	GUARNIZIONE	GASKET	JOINT PAPIER	DICHTUNG	JUNTA	
18	XII	TAPPO	PLUG	BOUCHON	VERSCHLUSS	TAPON	
19	XII	TAPPO	PLUG	BOUCHON	VERSCHLUSS	TAPON	
20	XII	GUARNIZIONE	GASKET	JOINT PAPIER	DICHTUNG	JUNTA	
21	XII	TAPPO	PLUG	BOUCHON	VERSCHLUSS	TAPON	
22	XII	GUARN OR					
23	XII	PIGNONE CONICO	BEVEL PINION	PIGNON CONIQUE	RITZEL KONISCHE		
24	XII	CUSCINETTO	BEARING	ROULEMENT	WÄLZLAGER	RODAMIENTO	
25	XII	TAPPO	PLUG	BOUCHON	VERSCHLUSS	TAPON	
26	XII	GUARNIZIONE	GASKET	JOINT PAPIER	DICHTUNG	JUNTA	
27	XII	VITE DI FISSAGGIO	SCREW	VIS	BEFESTIGUNGSSCHRAUBE	TORNILLO DE SUJECION	
28	XII	SUPPORTO FLAM	IEC FLANGE INPUT SUPPORT	SUPPORT BRIDE MOTEUR	AUFNAHME ANTRIEB IEC FLANSCH	SOPORTE FLAM	
29	XII	GUARNIZIONE	GASKET	JOINT PAPIER	DICHTUNG	JUNTA	
30	XII	TAPPO	PLUG	BOUCHON	VERSCHLUSS	TAPON	
31	XII	ALBERO ENTRATA	INPUT SHAFT	ARBRE ENTREE	ANTRIEBSWELLE	EJE ENTRADA	
32	XII	CUSCINETTO	BEARING	ROULEMENT	WÄLZLAGER	RODAMIENTO	
33	XII	SEEGER	CIRCLIP	CIRCLIP	SICHERUNGSRING	SEEGER	
34	XII	GUARN OR					
35	XII	ANELLO DI TENUTA	RUBBER SEAL RING	BASQUE D'ÉTANCHÉITÉ	DICHTUNGSRING		
36	XII	FLANGIA PAM	MOTORFLANGE	BRIDE MOTEUR	MOTOR FLANSCH	BRIDA PAM	
37	XII	VITE DI FISSAGGIO	SCREW	VIS	BEFESTIGUNGSSCHRAUBE	TORNILLO DE SUJECION	
38	XII	SEMIGIUNTO					

**TAVOLA XIII**

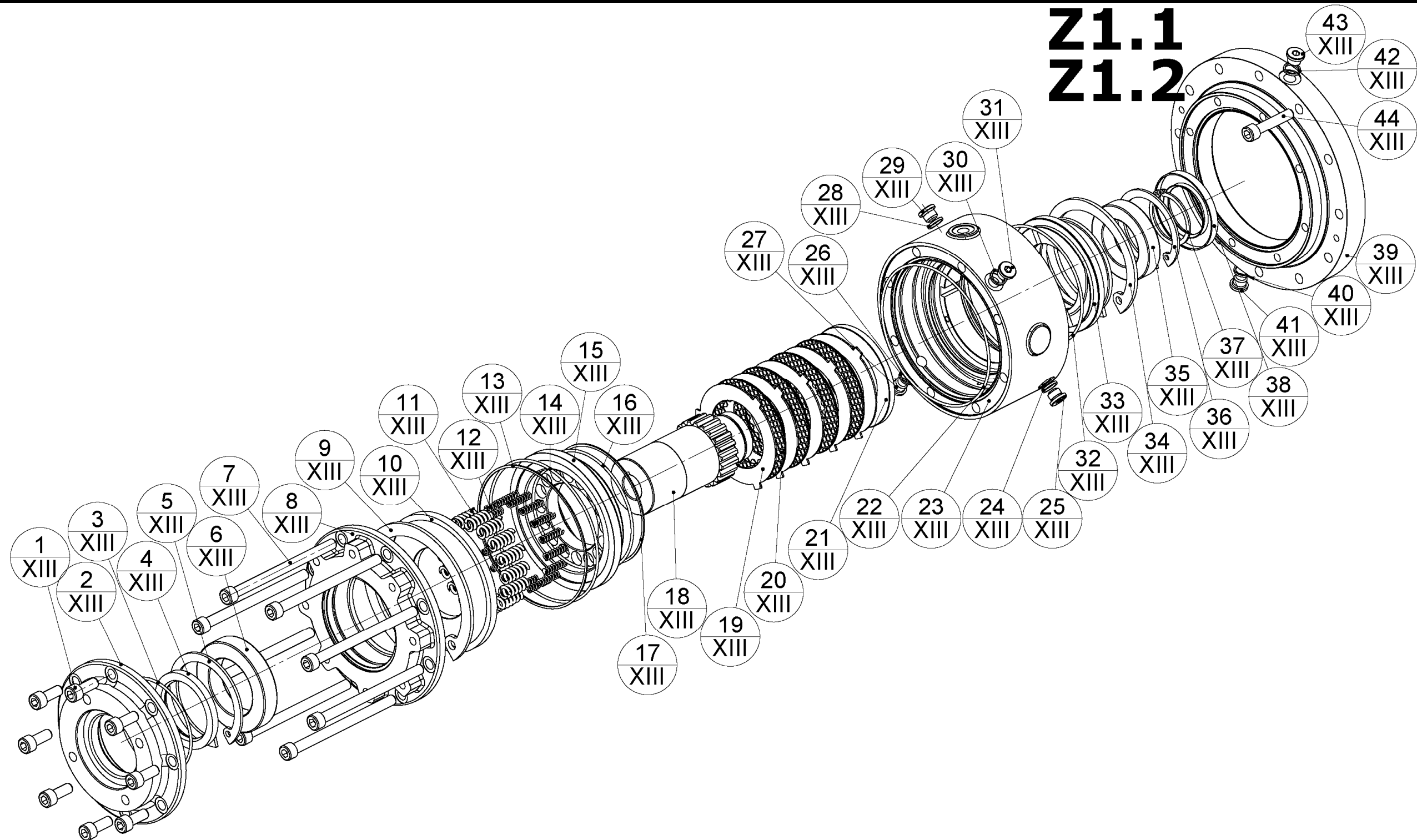

**TAV. XIII**



**PARTI DI RICAMBIO  
SPARE LISTS**

**NORM0265-R2**

Del 23/02/2012

Pag.36 di 43

STM spa  
VIA DEL MACCABRECCIA , 39  
40012 - CALDERARA DI RENO (BO)  
ITALY  
E-mail: [stm@stmspa.com](mailto:stm@stmspa.com)  
TEL ++ 39.051.646711 FAX ++ 39.051.6466178

EX

-

EX

**TAVOLA XIII**

ITEM	TAVOLA	DESCRIZIONE (I)	DESCRIPTION (GB)	DESIGNATION (F)	BEZEICHNUNG (D)	DENOMINACION (E)	NOTE
1	XIII	VITE DI FISSAGGIO	SCREW	VIS	BEFESTIGUNGSSCHRAUBE	TORNILLO DE SUJECION	
2	XIII	FLANGIA PAM	MOTORFLANGE	BRIDE MOTEUR	MOTOR FLANSCH	BRIDA PAM	
3	XIII	O-RING					
4	XIII	ANELLO DI TENUTA	RUBBER SEAL RING	BASQUE D'ÉTANCHÉITÉ	DICHTUNGSRING		
5	XIII	SEEGER	CIRCLIP	CIRCLIP	SICHERUNGSRING	SEEGER	
6	XIII	CUSCINETTO	BEARING	ROULEMENT	WÄZLAGER	RODAMIENTO	
7	XIII	VITE DI FISSAGGIO	SCREW	VIS	BEFESTIGUNGSSCHRAUBE	TORNILLO DE SUJECION	
8	XIII	SUPPORTO ALBERO ENTRATA	ECE SHAFT INPUT SUPPORT	SUPPORT ARBRE ENTREE	AUFNAHME ANTRIEB ECE WELLE	SUPL. EJE ENTRADA	
9	XIII	SEEGER	CIRCLIP	CIRCLIP	SICHERUNGSRING	SEEGER	
10	XIII	DISCO MOLLE					
11	XIII	MOLLA	SPRING				
12	XIII	MOLLA	SPRING				
13	XIII	ANELLO ANTIESTRUSIONE					
14	XIII	O-RING					
15	XIII	DISCO PORTA MOLLE					
16	XIII	O-RING					
17	XIII	ANELLO ANTIESTRUSIONE					
18	XIII	MANICOTTO	INPUT SHAFT IEC	MANCHON	ANTRIEBSWELLE IEC	MANGUITO	
19	XIII	DISCO MOBILE					
20	XIII	DISCO FRIZIONE					
21	XIII	DISTANZIALE	SPACER RING	ENTRETOISE	DISTANZSCHEIBE	ESPACIADOR	
22	XIII	O-RING					
23	XIII	SUPPORTO FRENI					
24	XIII	GUARNIZIONE	GASKET	JOINT PAPIER	DICHTUNG	JUNTA	
25	XIII	TAPPO	PLUG	BOUCHON	VERSCHLUSS	TAPON	
26	XIII	GUARNIZIONE	GASKET	JOINT PAPIER	DICHTUNG	JUNTA	
27	XIII	TAPPO	PLUG	BOUCHON	VERSCHLUSS	TAPON	
28	XIII	GUARNIZIONE	GASKET	JOINT PAPIER	DICHTUNG	JUNTA	
29	XIII	TAPPO	PLUG	BOUCHON	VERSCHLUSS	TAPON	
30	XIII	GUARNIZIONE	GASKET	JOINT PAPIER	DICHTUNG	JUNTA	
31	XIII	TAPPO	PLUG	BOUCHON	VERSCHLUSS	TAPON	
32	XIII	O-RING					
33	XIII	DISCO CHIUSURA					
34	XIII	SEEGER	CIRCLIP	CIRCLIP	SICHERUNGSRING	SEEGER	
35	XIII	CUSCINETTO	BEARING	ROULEMENT	WÄZLAGER	RODAMIENTO	
36	XIII	SEEGER	CIRCLIP	CIRCLIP	SICHERUNGSRING	SEEGER	
37	XIII	SEEGER	CIRCLIP	CIRCLIP	SICHERUNGSRING	SEEGER	
38	XIII	ANELLO DI TENUTA	RUBBER SEAL RING	BASQUE D'ÉTANCHÉITÉ	DICHTUNGSRING		
39	XIII	FLANGIA	FLANGE	BRIDE	FLANSCH	BRIDA	
40	XIII	GUARNIZIONE	GASKET	JOINT PAPIER	DICHTUNG	JUNTA	
41	XIII	TAPPO	PLUG	BOUCHON	VERSCHLUSS	TAPON	
42	XIII	GUARNIZIONE	GASKET	JOINT PAPIER	DICHTUNG	JUNTA	
43	XIII	TAPPO	PLUG	BOUCHON	VERSCHLUSS	TAPON	
44	XIII	VITE DI FISSAGGIO	SCREW	VIS	BEFESTIGUNGSSCHRAUBE	TORNILLO DE SUJECION	

### TAVOLA XV

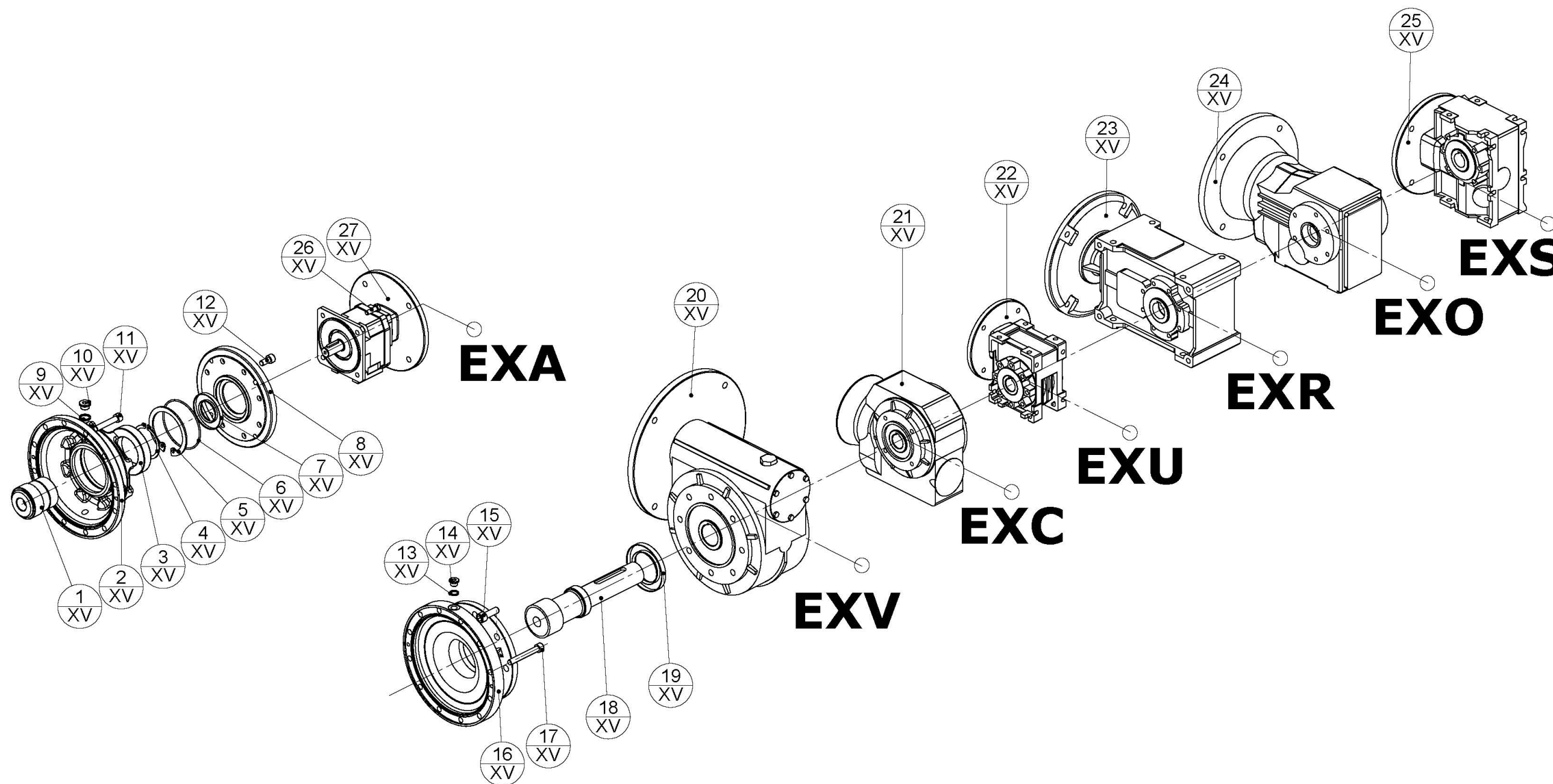

## TAV. XV



**PARTI DI RICAMBIO  
SPARE LISTS**

**NORM0265-R2**

Del 23/02/2012

Pag.38 di 43

STM spa  
VIA DEL MACCABRECCIA , 39  
40012 - CALDERARA DI RENO (BO)  
ITALY  
E-mail: [stm@stmspa.com](mailto:stm@stmspa.com)  
TEL ++ 39 051.646711 FAX ++ 39 051.6466178

EX

-

EX

**TAVOLA XV**

ITEM	TAVOLA	DESCRIZIONE ( I )	DESCRIPTION ( GB )	DESIGNATION ( F )	BEZEICHNUNG ( D )	DENOMINACION ( E )	NOTE
1	XV	MANICOTTO	INPUT SHAFT IEC	MANCHON	ANTRIEBSWELLE IEC	MANGUITO	
2	XV	SUPPORTO ALBERO ENTRATA	ECE SHAFT INPUT SUPPORT	SUPPORT ARBRE ENTREE	AUFNAHME ANTRIEB ECE WELLE	SUPL. EJE ENTRADA	
3	XV	CUSCINETTO	BEARING	ROULEMENT	WÄLZLAGER	RODAMIENTO	
4	XV	SEEGER	CIRCLIP	CIRCLIP	SICHERUNGSRING	SEEGER	
5	XV	SEEGER	CIRCLIP	CIRCLIP	SICHERUNGSRING	SEEGER	
6	XV	O-RING					
7	XV	ANELLO DI TENUTA	RUBBER SEAL RING	BASQUE D'ÉTANCHÉITÉ	DICHTUNGSRING		
8	XV	FLANGIA PAM	MOTORFLANGE	BRIDE MOTEUR	MOTOR FLANSCH	BRIDA PAM	
9	XV	GUARNIZIONE	GASKET	JOINT PAPIER	DICHTUNG	JUNTA	
10	XV	TAPPO	PLUG	BOUCHON	VERSCHLUSS	TAPON	
11	XV	VITE DI FISSAGGIO	SCREW	VIS	BEFESTIGUNGSSCHRAUBE	TORNILLO DE SUJECION	
12	XV	VITE DI FISSAGGIO	SCREW	VIS	BEFESTIGUNGSSCHRAUBE	TORNILLO DE SUJECION	
13	XV	GUARNIZIONE	GASKET	JOINT PAPIER	DICHTUNG	JUNTA	
14	XV	TAPPO	PLUG	BOUCHON	VERSCHLUSS	TAPON	
15	XV	VITE DI FISSAGGIO	SCREW	VIS	BEFESTIGUNGSSCHRAUBE	TORNILLO DE SUJECION	
16	XV	FLANGIA DI COMBINAZIONE	FLANGE COMBINATION CRMI	BRIDE DE LIAISON	FLANSCH KOMBINATION CRMI	BRIDA DE COMBINACION	
17	XV	VITE DI FISSAGGIO	SCREW	VIS	BEFESTIGUNGSSCHRAUBE	TORNILLO DE SUJECION	
18	XV	SOLARE	SUN				
19	XV	ANELLO DI TENUTA	RUBBER SEAL RING	BASQUE D'ÉTANCHÉITÉ	DICHTUNGSRING		
20	XV	EXV					R
21	XV	EXC					CR
22	XV	EXU					U
23	XV	EXR					RX
24	XV	EXO					O
25	XV	EXS					S
26	XV	VITE DI FISSAGGIO	SCREW	VIS	BEFESTIGUNGSSCHRAUBE	TORNILLO DE SUJECION	
27	XV	EXA					A

**TAVOLA XVI**

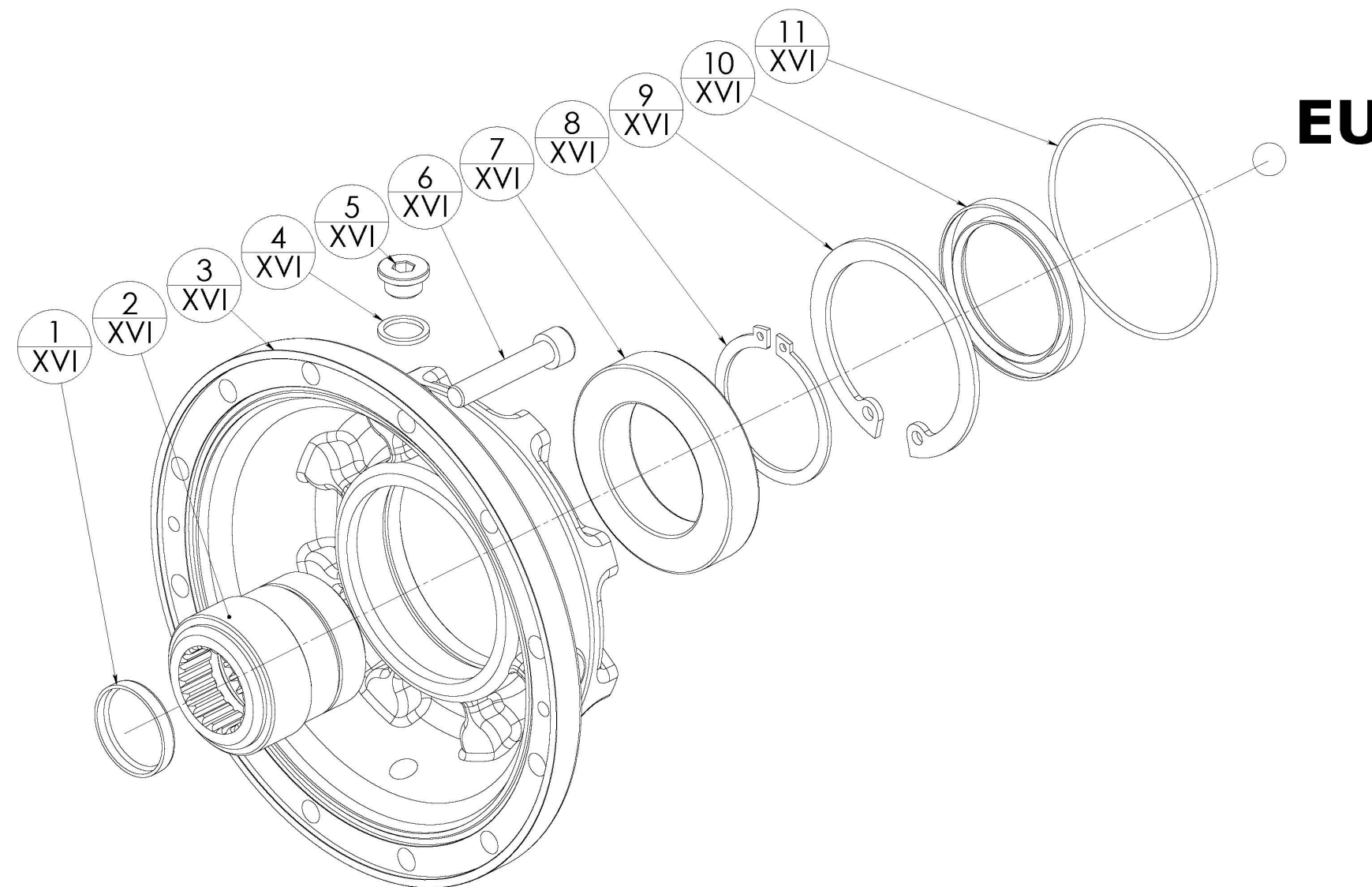

**TAV. XVI**

**TAVOLA XVI**

ITEM	TAVOLA	DESCRIZIONE (I)	DESCRIPTION (GB)	DESIGNATION (F)	BEZEICHNUNG (D)	DENOMINACION (E)	NOTE
1	XVI	TAPPO	PLUG	BOUCHON	VERSCHLUSS	TAPON	
2	XVI	MANICOTTO	INPUT SHAFT IEC	MANCHON	ANTRIEBSWELLE IEC	MANGUITO	
3	XVI	SUPPORTO ALBERO ENTRATA	ECE SHAFT INPUT SUPPORT	SUPPORT ARBRE ENTREE	AUFNAHME ANTRIEB ECE WELLE	SUPL. EJE ENTRADA	
4	XVI	GUARNIZIONE	GASKET	JOINT PAPIER	DICHTUNG	JUNTA	
5	XVI	TAPPO	PLUG	BOUCHON	VERSCHLUSS	TAPON	
6	XVI	VITE DI FISSAGGIO	SCREW	VIS	BEFESTIGUNGSSCHRAUBE	TORNILLO DE SUJECION	
7	XVI	CUSCINETTO	BEARING	ROULEMENT	WÄZLAGER	RODAMIENTO	
8	XVI	SEEGER	CIRCLIP	CIRCLIP	SICHERUNGSRING	SEEGER	
9	XVI	SEEGER	CIRCLIP	CIRCLIP	SICHERUNGSRING	SEEGER	
10	XVI	ANELLO DI TENUTA	RUBBER SEAL RING	BASQUE D'ÉTANCHÉITÉ	DICHTUNGSRING		
11	XVI	GUARN OR					



### TAVOLA XVII

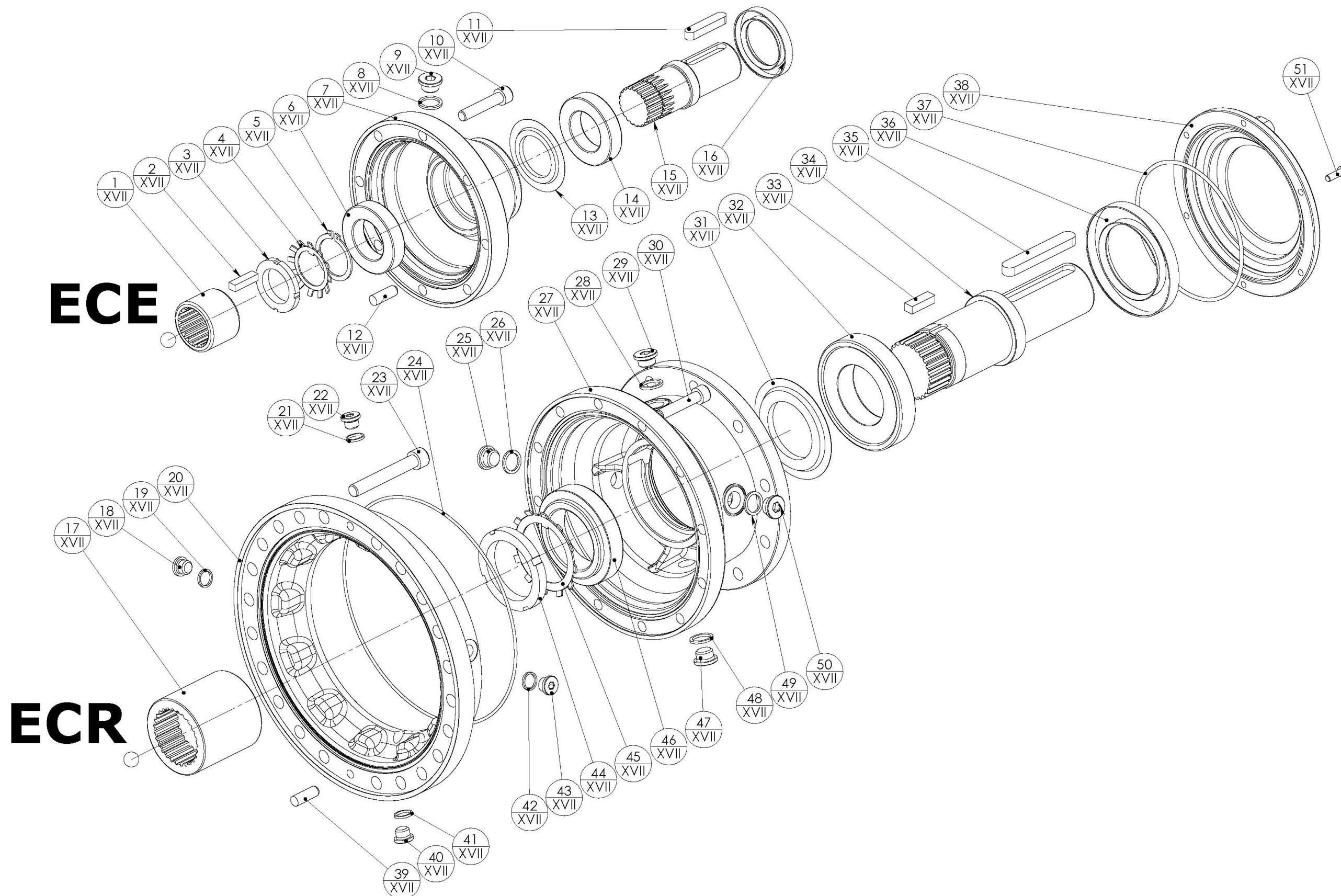

### TAV. XVII



**PARTI DI RICAMBIO  
SPARE LISTS**

**NORM0265-R2**  
Del 23/02/2012  
Pag.41 di 43

STM spa  
VIA DEL MACCABRECCIA , 39  
40012 - CALDERARA DI RENO (BO)  
ITALY  
E-mail: [stm@stmspa.com](mailto:stm@stmspa.com)  
TEL ++ 39 051.646711 FAX ++ 39 051.6466178

EX

EX

**TAVOLA XVII**

**ECE**

ITEM	TAVOLA	DESCRIZIONE (I)	DESCRIPTION (GB)	DESIGNATION (F)	BEZEICHNUNG (D)	DENOMINACION (E)	NOTE
1	XVII	BUSSOLA	BUSHING	PIECE DE POUSSEE ROUE LIMIT.	BUCHSE	BUJE	
2	XVII	LINGUETTA	KEY				
3	XVII	GHIERA DI REGOLAZIONE	ADJUSTMENT GROOVE NUT	FRETTE DE REGLAGE	EINSTELL-NUTMUTTER	TUERCA ACANALADA	
4	XVII	ROSETTA SICUREZZA					
5	XVII	SEEGER	CIRCLIP	CIRCLIP	SICHERUNGSRING	SEEGER	
6	XVII	CUSCINETTO	BEARING	ROULEMENT	WÄZLAGER	RODAMIENTO	
7	XVII	SUPPORTO ALBERO ENTRATA	ECE SHAFT INPUT SUPPORT	SUPPORT ARBRE ENTREE	AUFNAHME ANTRIEB ECE WELLE	SUPL. EJE ENTRADA	
8	XVII	GUARNIZIONE	GASKET	JOINT PAPIER	DICHTUNG	JUNTA	
9	XVII	TAPPO	PLUG	BOUCHON	VERSCHLUSS	TAPON	
10	XVII	VITE DI FISSAGGIO	SCREW	VIS	BEFESTIGUNGSSCHRAUBE	TORNILLO DE SUJECION	
11	XVII	LINGUETTA	KEY	CLAVETTE	PASSFEDER	CHAVETA	
12	XVII	SPINA	PIN				
13	XVII	ANELLO NILOS	NILOS RING				
14	XVII	CUSCINETTO	BEARING	ROULEMENT	WÄZLAGER	RODAMIENTO	
15	XVII	ALBERO ENTRATA	INPUT SHAFT	ARBRE ENTREE	ANTRIEBSWELLE	EJE ENTRADA	
16	XVII	ANELLO DI TENUTA	RUBBER SEAL RING	BASQUE D'ÉTANCHÉITÉ	DICHTUNGSRING		

**ECR**

17	XVII	BUSSOLA	BUSHING	PIECE DE POUSSEE ROUE LIMIT.	BUCHSE	BUJE	
18	XVII	TAPPO	PLUG	BOUCHON	VERSCHLUSS	TAPON	
19	XVII	GUARNIZIONE	GASKET	JOINT PAPIER	DICHTUNG	JUNTA	
20	XVII	FLANGIA DI COMBINAZIONE	COMBINE FLANGE				
21	XVII	GUARNIZIONE	GASKET	JOINT PAPIER	DICHTUNG	JUNTA	
22	XVII	TAPPO	PLUG	BOUCHON	VERSCHLUSS	TAPON	
23	XVII	VITE DI FISSAGGIO	SCREW	VIS	BEFESTIGUNGSSCHRAUBE	TORNILLO DE SUJECION	
24	XVII	GUARN OR					
25	XVII	TAPPO	PLUG	BOUCHON	VERSCHLUSS	TAPON	
26	XVII	GUARNIZIONE	GASKET	JOINT PAPIER	DICHTUNG	JUNTA	
27	XVII	SUPPORTO ALBERO ENTRATA	ECR SHAFT INPUT SUPPORT				
28	XVII	GUARNIZIONE	GASKET	JOINT PAPIER	DICHTUNG	JUNTA	
29	XVII	TAPPO	PLUG	BOUCHON	VERSCHLUSS	TAPON	
30	XVII	VITE DI FISSAGGIO	SCREW	VIS	BEFESTIGUNGSSCHRAUBE	TORNILLO DE SUJECION	
31	XVII	ANELLO NILOS	NILOS RING				
32	XVII	CUSCINETTO	BEARING	ROULEMENT	WÄZLAGER	RODAMIENTO	
33	XVII	LINGUETTA	KEY	CLAVETTE	PASSFEDER	CHAVETA	
34	XVII	ALBERO ENTRATA	INPUT SHAFT	ARBRE ENTREE	ANTRIEBSWELLE	EJE ENTRADA	
35	XVII	LINGUETTA	KEY	CLAVETTE	PASSFEDER	CHAVETA	
36	XVII	ANELLO DI TENUTA	RUBBER SEAL RING	BASQUE D'ÉTANCHÉITÉ	DICHTUNGSRING		
37	XVII	GUARN OR					
38	XVII	COPERCHIO	COVER				
39	XVII	SPINA	PIN				
40	XVII	TAPPO	PLUG	BOUCHON	VERSCHLUSS	TAPON	
41	XVII	GUARNIZIONE	GASKET	JOINT PAPIER	DICHTUNG	JUNTA	
42	XVII	GUARNIZIONE	GASKET	JOINT PAPIER	DICHTUNG	JUNTA	
43	XVII	TAPPO	PLUG	BOUCHON	VERSCHLUSS	TAPON	
44	XVII	GHIERA DI REGOLAZIONE	ADJUSTMENT GROOVE NUT	FRETTE DE REGLAGE	EINSTELL-NUTMUTTER	TUERCA ACANALADA	
45	XVII	ROSETTA SICUREZZA					
46	XVII	CUSCINETTO	BEARING	ROULEMENT	WÄZLAGER	RODAMIENTO	
47	XVII	TAPPO	PLUG	BOUCHON	VERSCHLUSS	TAPON	
48	XVII	GUARNIZIONE	GASKET	JOINT PAPIER	DICHTUNG	JUNTA	
49	XVII	GUARNIZIONE	GASKET	JOINT PAPIER	DICHTUNG	JUNTA	
50	XVII	TAPPO	PLUG	BOUCHON	VERSCHLUSS	TAPON	



**PARTI DI RICAMBIO  
SPARE LISTS**

**NORM0265-R2**  
Del 23/02/2012  
Pag.42 di 43

STM spa  
VIA DEL MACCABRECCIA, 39  
40012 - CALDERARA DI RENO (BO)  
ITALY  
E-mail: [stm@stmspa.com](mailto:stm@stmspa.com)  
TEL. ++39.051.6467111 FAX. ++39.051.6466178

EX

-

EX

**TAVOLA XVII**

51	XVII	VITE DI FISSAGGIO	SCREW	VIS	BEFESTIGUNGSSCHRAUBE	TORNILLO DE SUJECION
----	------	-------------------	-------	-----	----------------------	----------------------

## TAVOLA XVIII

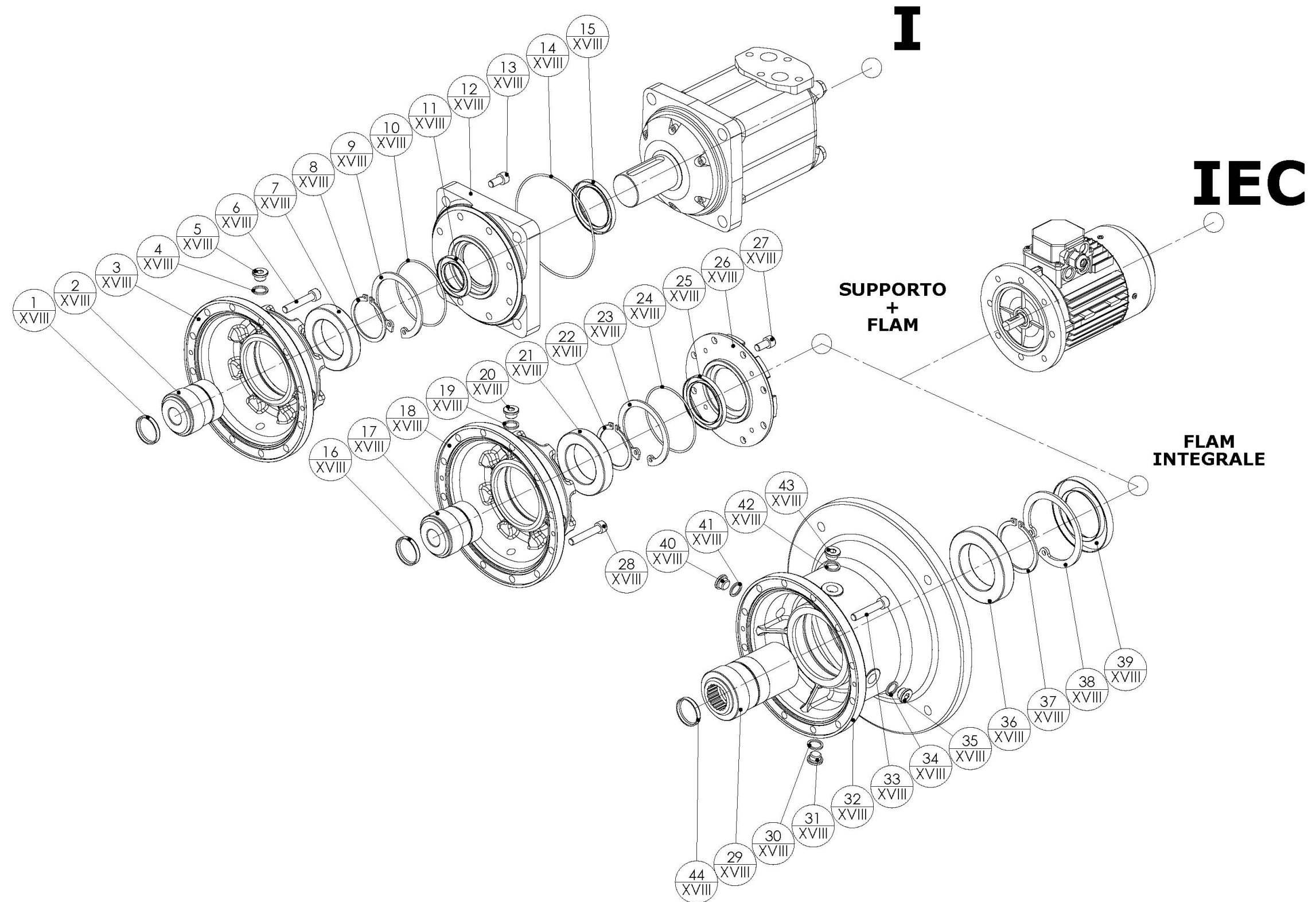

# TAV. XVIII



**PARTI DI RICAMBIO  
SPARE LISTS**

**NORM0265-R2**

Del 23/02/2012

Pag.44 di 43

STM spa  
VIA DEL MACCABRECCIA , 39  
40012 - CALDERARA DI RENO (BO)  
ITALY  
E-mail: [stm@stmspa.com](mailto:stm@stmspa.com)  
TEL ++ 39 051.646711 FAX ++ 39 051.6466178

EX

EX

**TAVOLA XVIII**

**I**

ITEM	TAVOLA	DESCRIZIONE ( I )	DESCRIPTION ( GB )	DESIGNATION ( F )	BEZEICHNUNG ( D )	DENOMINACION ( E )	NOTE
1	XVIII	TAPPO GOMMA	RUBBER COVER				
2	XVIII	MANICOTTO	INPUT SHAFT IEC	MANCHON	ANTRIEBSWELLE IEC	MANGUITO	
3	XVIII	SUPPORTO ALBERO ENTRATA	ECE SHAFT INPUT SUPPORT	SUPPORT ARBRE ENTREE	AUFNAHME ANTRIEB ECE WELLE	SUPL. EJE ENTRADA	
4	XVIII	GUARNIZIONE	GASKET	JOINT PAPIER	DICHTUNG	JUNTA	
5	XVIII	TAPPO	PLUG	BOUCHON	VERSCHLUSS	TAPON	
6	XVIII	VITE DI FISSAGGIO	SCREW	VIS	BEFESTIGUNGSSCHRAUBE	TORNILLO DE SUJECION	
7	XVIII	CUSCINETTO	BEARING	ROULEMENT	WÄZLAGER	RODAMIENTO	
8	XVIII	SEEGER	CIRCLIP	CIRCLIP	SICHERUNGSRING	SEEGER	
9	XVIII	SEEGER	CIRCLIP	CIRCLIP	SICHERUNGSRING	SEEGER	
10	XVIII	O-RING					
11	XVIII	ANELLO DI TENUTA	RUBBER SEAL RING	BASQUE D'ÉTANCHÉITÉ	DICHTUNGSRING		
12	XVIII	FLANGIA PAM	MOTORFLANGE	BRIDE MOTEUR	MOTOR FLANSCH	BRIDA PAM	
13	XVIII	VITE DI FISSAGGIO	SCREW	VIS	BEFESTIGUNGSSCHRAUBE	TORNILLO DE SUJECION	
14	XVIII	O-RING					
15	XVIII	ANELLO DI TENUTA	RUBBER SEAL RING	BASQUE D'ÉTANCHÉITÉ	DICHTUNGSRING		

**IEC SUPPORTO + FLAM**

16	XVIII	TAPPO GOMMA	RUBBER COVER				
17	XVIII	MANICOTTO	INPUT SHAFT IEC	MANCHON	ANTRIEBSWELLE IEC	MANGUITO	
18	XVIII	SUPPORTO ALBERO ENTRATA	ECE SHAFT INPUT SUPPORT	SUPPORT ARBRE ENTREE	AUFNAHME ANTRIEB ECE WELLE	SUPL. EJE ENTRADA	
19	XVIII	GUARNIZIONE	GASKET	JOINT PAPIER	DICHTUNG	JUNTA	
20	XVIII	TAPPO	PLUG	BOUCHON	VERSCHLUSS	TAPON	
21	XVIII	CUSCINETTO	BEARING	ROULEMENT	WÄZLAGER	RODAMIENTO	
22	XVIII	SEEGER	CIRCLIP	CIRCLIP	SICHERUNGSRING	SEEGER	
23	XVIII	SEEGER	CIRCLIP	CIRCLIP	SICHERUNGSRING	SEEGER	
24	XVIII	O-RING					
25	XVIII	ANELLO DI TENUTA	RUBBER SEAL RING	BASQUE D'ÉTANCHÉITÉ	DICHTUNGSRING		
26	XVIII	FLANGIA PAM	MOTORFLANGE	BRIDE MOTEUR	MOTOR FLANSCH	BRIDA PAM	
27	XVIII	VITE DI FISSAGGIO	SCREW	VIS	BEFESTIGUNGSSCHRAUBE	TORNILLO DE SUJECION	
28	XVIII	VITE DI FISSAGGIO	SCREW	VIS	BEFESTIGUNGSSCHRAUBE	TORNILLO DE SUJECION	

**IEC FLAM INTEGRALE**

29	XVIII	MANICOTTO	INPUT SHAFT IEC	MANCHON	ANTRIEBSWELLE IEC	MANGUITO	
30	XVIII	GUARNIZIONE	GASKET	JOINT PAPIER	DICHTUNG	JUNTA	
31	XVIII	TAPPO	PLUG	BOUCHON	VERSCHLUSS	TAPON	
32	XVIII	FLANGIA PAM	MOTORFLANGE	BRIDE MOTEUR	MOTOR FLANSCH	BRIDA PAM	
33	XVIII	VITE DI FISSAGGIO	SCREW	VIS	BEFESTIGUNGSSCHRAUBE	TORNILLO DE SUJECION	
34	XVIII	GUARNIZIONE	GASKET	JOINT PAPIER	DICHTUNG	JUNTA	
35	XVIII	TAPPO	PLUG	BOUCHON	VERSCHLUSS	TAPON	
36	XVIII	CUSCINETTO	BEARING	ROULEMENT	WÄZLAGER	RODAMIENTO	
37	XVIII	SEEGER	CIRCLIP	CIRCLIP	SICHERUNGSRING	SEEGER	
38	XVIII	SEEGER	CIRCLIP	CIRCLIP	SICHERUNGSRING	SEEGER	
39	XVIII	ANELLO DI TENUTA	RUBBER SEAL RING	BASQUE D'ÉTANCHÉITÉ	DICHTUNGSRING		
40	XVIII	TAPPO	PLUG	BOUCHON	VERSCHLUSS	TAPON	
41	XVIII	GUARNIZIONE	GASKET	JOINT PAPIER	DICHTUNG	JUNTA	
42	XVIII	GUARNIZIONE	GASKET	JOINT PAPIER	DICHTUNG	JUNTA	
43	XVIII	TAPPO	PLUG	BOUCHON	VERSCHLUSS	TAPON	
44	XVIII	TAPPO	PLUG	BOUCHON	VERSCHLUSS	TAPON	

TAVOLA XIX

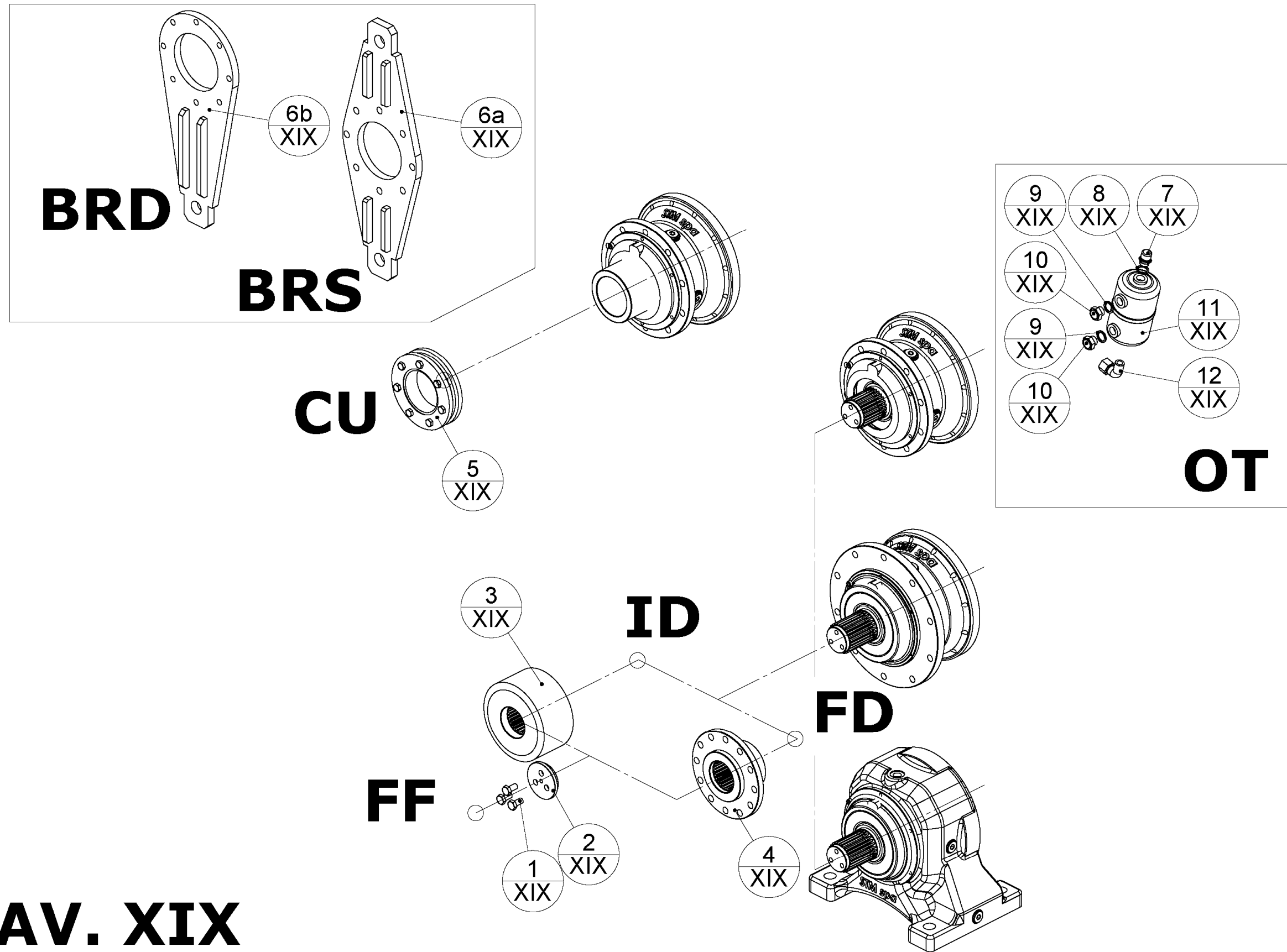

TAV. XIX



**PARTI DI RICAMBIO  
SPARE LISTS**

**NORM0265-R2**

Del 23/02/2012

Pag.46 di 43

STM spa  
VIA DEL MACCABRECCIA , 39  
40012 - CALDERARA DI RENO (BO)  
ITALY  
E-mail: [stm@stmspa.com](mailto:stm@stmspa.com)  
TEL ++ 39.051.646711 FAX ++ 39.051.6466178

EX

-

EX

**TAVOLA XIX**

<i>ITEM</i>	<i>TAVOLA</i>	<i>DESCRIZIONE ( I )</i>	<i>DESCRIPTION ( GB )</i>	<i>DESIGNATION ( F )</i>	<i>BEZEICHNUNG ( D )</i>	<i>DENOMINACION ( E )</i>	<i>NOTE</i>
1	XIX	VITE DI FISSAGGIO	SCREW	VIS	BEFESTIGUNGSSCHRAUBE	TORNILLO DE SUJECION	
2	XIX	RONDELLA	WASHER	RONDELLE	UNTERLEGSCHIEBE	ARANDELA	
3	XIX	PIEDE	FOOT	PATTE	FUSS	PIE	
4	XIX	FLANGIA	FLANGE	BRIDE	FLANSCH	BRIDA	
5	XIX	CALETTATORE	SHRINK DISC	FRETTE DE SERRAGE	SCHRUMPFSCHEIBE	EMPALMADOR	
6 a	XIX	BRACCIO DI REAZIONE	TORQUE ARM	BRAS DE COUPLE	DREHMOMENTSTUTZE		
6 b	XIX	BRACCIO DI REAZIONE	TORQUE ARM	BRAS DE COUPLE	DREHMOMENTSTUTZE		
7	XIX	TAPPO	PLUG	BOUCHON	VERSCHLUSS	TAPON	
8	XIX	GUARNIZIONE	GASKET	JOINT PAPIER	DICHTUNG	JUNTA	
9	XIX	GUARNIZIONE	GASKET	JOINT PAPIER	DICHTUNG	JUNTA	
10	XIX	TAPPO	PLUG	BOUCHON	VERSCHLUSS	TAPON	
11	XIX	VASO D'ESPANSIONE					
12	XIX	RACCORDO					